



TECHNOLOGY
SUBJECTS
SUPPORT
SERVICE

Leaving Certificate

Technology

CNC Routing & Applications

Denford Compact 1000 Pro

Contents

Applications of CAD/Cam in Schools	1
Types of CNC Machines	1
CNC Routers/Mills	3
CNC Routing – Introduction	9
Characteristics of the Denford Compact 1000 Pro	9
Operation of the Machine.....	10
2D Machining	15
2D Machining Exercise	18
Working with VR Milling	28
Projects	31
PCB Manufacture.....	32
Designing and Manufacturing a PCB	34
Machining the PCB	39
Appendix 1	45
Appendix 2.....	51
Origins of CAD/CAM	58

Applications of CAD/CAM in Schools

This section will first look at the types of CNC machines commonly used in a school setting. Then, for each type of machine, an overview is given of the range of processes possible for it. For many of the processes the starting point will be a CAD model or drawing. The workings of CAD systems are not discussed here.

Types of CNC Machine

There are three common types of CNC machines used in the classroom. In each case they can greatly simplify the manufacture of an item or in many cases permit the manufacture of an item that would otherwise be impossible. The applications of each are described below.

CNC Lathes

These will be a familiar item to many people as they have been in Engineering rooms in schools for many years. The most useful application is in the production of parts that have radiused corners, tapers and threads that are difficult to produce otherwise. Boxford and EMCO are the two most common manufacturers and are described in more detail in a later section.

Laser Technology

Laser is a relatively new technology in the classroom and offers a very versatile and easy means of producing items from wood and plastic materials. The machines are very easy to set up and use (there is no need to clamp the work piece) and behave in much the same way as a printer or plotter. The laser machine is driven directly from the CAD system or graphical package being used.



Figure 1 Laser cutting machine

There are two main applications for laser machines:

1. Laser Cutting

Laser cutting is quick, accurate and leaves a clean cut. It is useful for producing components that would otherwise be marked, cut and filed to size. It allows intricate parts to be cut that would otherwise be very difficult to manufacture. Laser offers an attractive alternative to milling for acrylic or wood based materials.

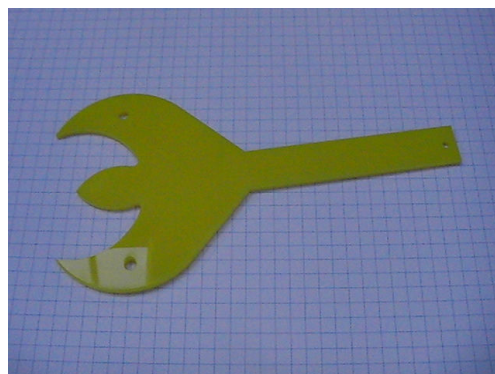
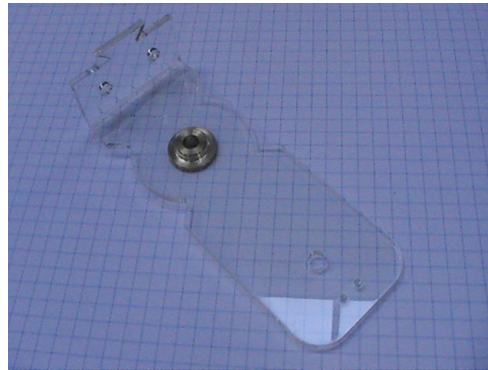

Figure 2 Laser cut parts from Acrylic

2. Laser Engraving

It is possible to take an image such as a photograph or other graphical image and engrave it onto wood or plastic using a slightly different machine setting than that used for cutting. The quality of the image produced is very good.



Figure 3 Laser engraved image onto clear acrylic

CNC Routers / Mills

A router can be classed as a type of milling machine that allows very fast cutter travel combined with very high spindle speeds. However routers have a relatively low stiffness compared with a conventional machine. These machines are ideal for machining plastics, wood, modelling foam etc. but usually are limited to non-ferrous metals at best due to the lack of rigidity. A desktop router typically comes with an impressive set of software and ancillary equipment, considering the low cost. They are extremely versatile and can be used for a variety of purposes. A typical machine will offer the following capabilities.

2-D Profile Cutting

CNC routers can be used to machine shapes consisting of lines, arcs and curves from sheet material. The machine is usually driven by a 2-D machining software package such as TechSoft 2-D design. This allows the profiles of the items to be imported from a CAD system and cut on the machine. Features such as holes, pockets and bosses can be produced as well. The user interface of these packages is often basic and drawing and editing of complex shapes is best completed before exporting the data from the CAD system.

PCB Manufacture

Manufacturing a PCB from copper clad board allows versatility in Technology projects where a pupil can design a circuit and then manufacture a PCB to fit a particular project or application. Because there are no toxic chemicals involved (as is the case with PCB etching) it is a very suitable process for the classroom.

In order to manufacture the PCB a specialist PCB manufacturing software package is used. One such package is TechSoft PCB design and make. The PCB design is generated beforehand using software such as PCB Wizard or Circuit Wizard and then imported into PCB Design and Make. From there it is a relatively simple matter to machine the tracks and holes as the software handles the details of tool offsets, cut depths, sequencing etc.

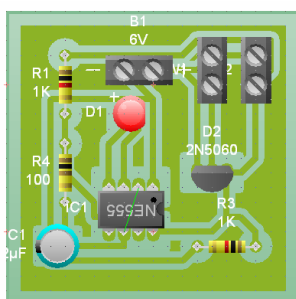

PCB Design

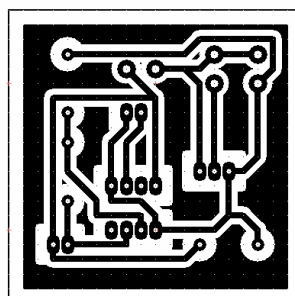

PCB Artwork

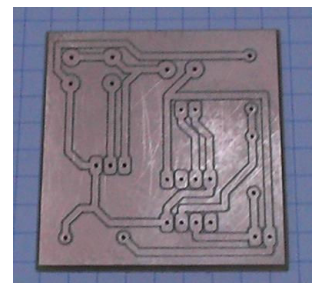

Machined PCB

Figure 4 Stages in PCB manufacture

3-D Machining

Machining of complex parts such as forms for vacuum forming, moulds and models requires a 3-D machining software package. This differs from the 2-D software in that it can import a three dimensional representation of the part to be made rather than just a two dimensional profile as previously. The starting point is to generate a solid model of the item to be made using CAD software such as SolidWorks. This is then exported into the 3-D software where toolpaths are generated for both the roughing and finishing of the item. The software is often wizard based and leads the user through a series of logical steps through the process of preparing the machining sequence. Graphical simulation of the toolpath allows a realistic preview of the part to be generated. 3-D machining is one of the most powerful features of the desktop router and should contribute significantly to the development of Technology projects.

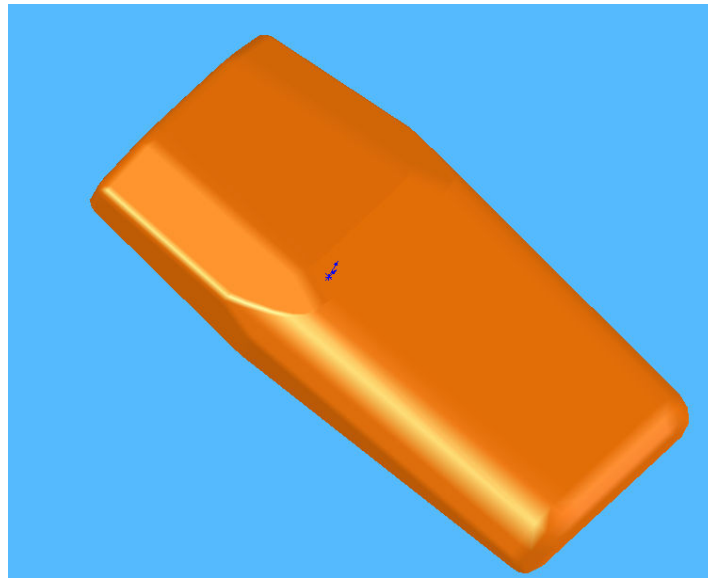

Figure 5 CAD model of part

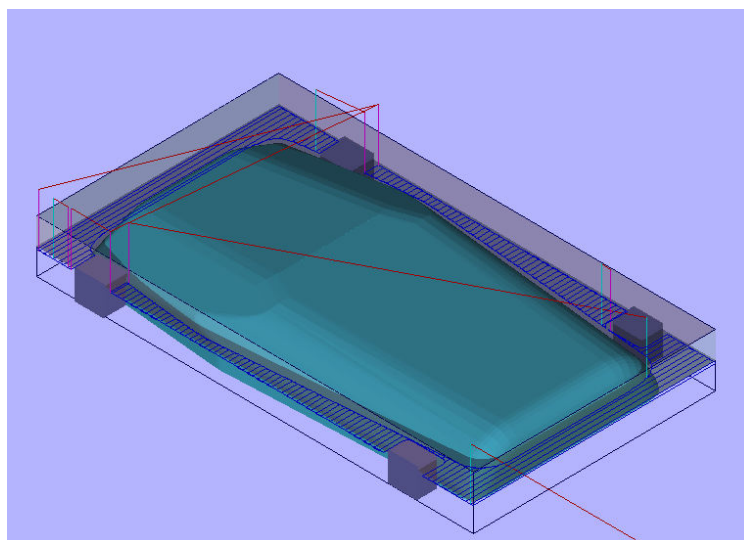

Figure 6 Model of part showing toolpath



Figure 7 Machined part

3-D Scanning

In 3-D scanning an existing component can be reverse engineered by using a touch probe to capture a grid of points on its surface and store them as a CAD model. This is particularly useful where an existing complex part exists that needs to be copied or have something machined or engraved onto its surface. The way of making a 3-D scan is not very different from using a 2-D scanner to scan a document. The main difference is the third dimension. In a conventional scan, the area of the page to be scanned is defined before performing the scan. With 3-D scanning, it is necessary to define a box around the volume to be scanned in the X, Y and Z directions. This is easily done once the size and position of the item on the machine table is known. One important issue with 3-D scanning is the usability of the file once it is imported into the CAD system. Often the amount of editing that can be done to the CAD model is limited, particularly in systems such as SolidWorks that are based on parametric design. However for simple applications such as with engraving packages the scanned file is perfectly acceptable.

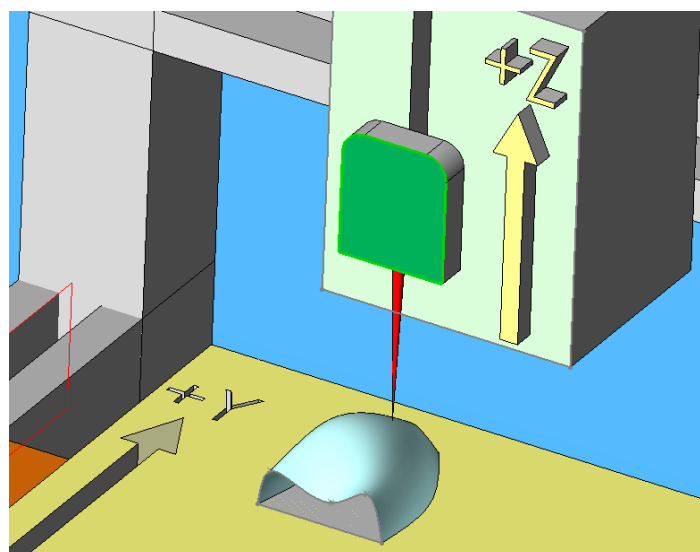

Figure 8 Touch probe and part to be scanned

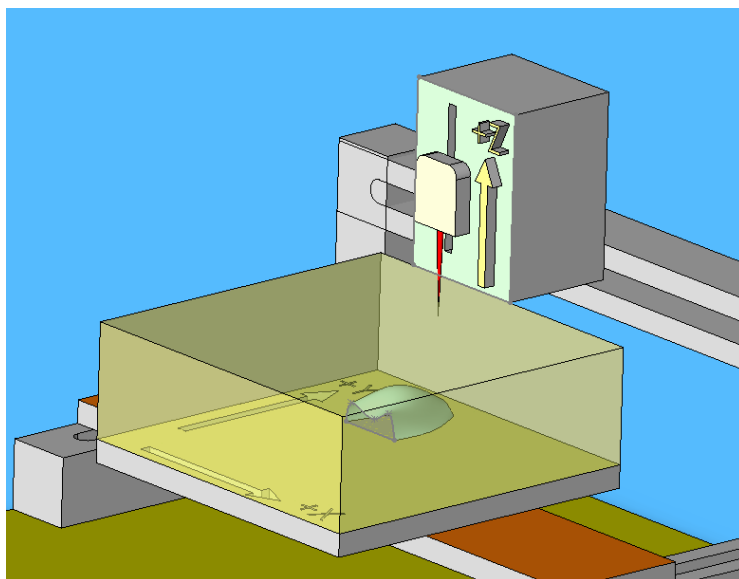

Figure 9 The default scanning volume is the entire motion envelope of the machine

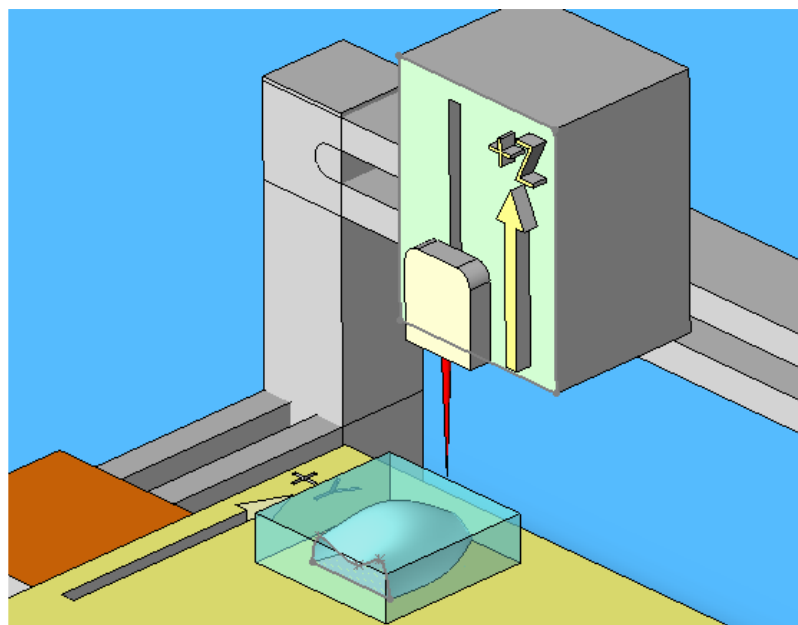

Figure 10 Small envelope confining scanning to the volume of the component

Engraving, Carving, Lithopane Machining.

These processes may be less familiar than the more common applications for routers but offer a wide range of opportunities in the classroom. They all share one thing in common. They involve taking a 2-D object such as a photograph or profile and giving it a third dimension. This '3-D' object is then projected onto a surface or a plane (depending on the application) and then machined into it. In each case a specialist software application is needed. These engraving software systems are usually limited in what they do (e.g. engraving only) due to the degree of specialism involved. However they are easy to use and can produce spectacular results. Each is discussed in more detail below.

Engraving

Engraving is a means of creating reliefs (raised engravings) and engravings on flat and curved surfaces. Items such as text or a 2-D profile are given a thickness and then projected onto the surface of the object to be machined. Items such as text or line drawings are commonly used to make engravings. Engravings can be made on existing solid objects if the surface of the object to be engraved can be captured using a 3-D scanner (see above) beforehand. Images can also be engraved onto surfaces generated in CAD.

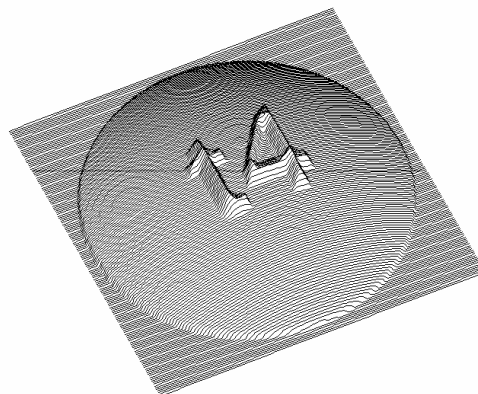

Figure 11 Relief on a curved surface

Lithopane Machining

A Lithopane is a special form of image where a greyscale can be reproduced by machining a translucent material to varying depths. The deeper the cut, the thinner the remaining material and the more light that can pass through it. By varying the depth of cut lighter and darker areas can be produced. When lit from behind the image is visible. High quality monochrome images can be produced in this way.



Figure 12 Lithopane machined from translucent plastic back-lit and mounted in a frame

Lithopane machining is very easy to do using the specialist software accompanying Denford and TechSoft routers. It involves taking a scanned image or digital photograph, converting it to a greyscale, projecting it onto a plane and letting the software generate the cut depths and toolpath.

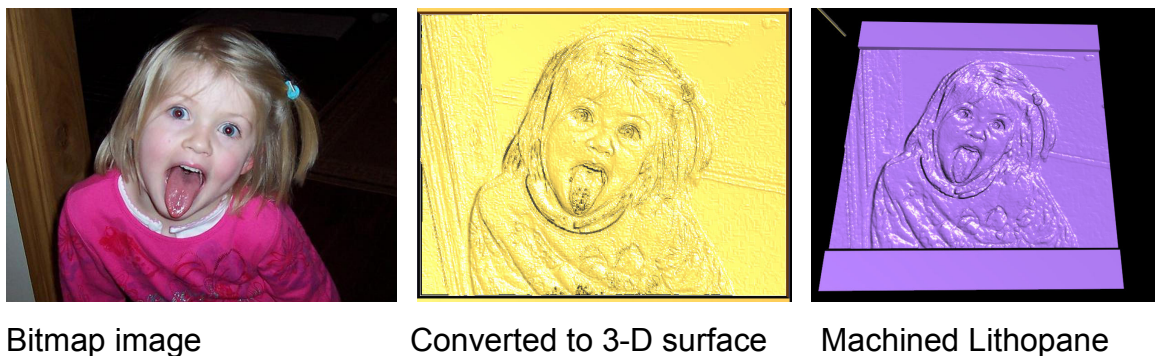

Figure 13 Stages in the production of a lithopane image

Production of a lithopane is very easy and quick and is expedited by a 'Wizard' that moves through the process step by step.

CNC Routing – Introduction

This section deals with using the Denford Compact 1000 Pro routing machine and the material contained here is specific to it. Denford provide a comprehensive set of tutorials for using the various options and it is recommended that these are worked through thoroughly.



The three important software packages needed to use the Denford are as follows:

Software	Application
QuickCAM 2D Design	2-D profiling work
QuickCAM Pro	3D Machining Lithopane Machining
VR Milling V5	Provides the Machine Interface Simulates Virtual Machine Output from the QuickCAM systems is directed to VR Milling for output to the CNC. Wizard for PCB production

Characteristics of the Denford Compact 1000 Pro Router

The Denford Compact 1000 Pro is a three axis routing machine. The table area is 400mm x 240mm with a working height of 80mm approximately. The machine head is mounted on a gantry which provides movement along the X axis. The machine table moves to provide a Y axis. The head can travel upwards and downwards to provide the Z axis. The machine spindle can hold tools up to 13mm diameter and rotates at 18,000 rev/min. The tool can travel at up to 4,000mm/min in the X and Y axes. This is faster than a conventional metal cutting milling machine. The machine can cut soft materials e.g. plastics and wood but as well as non-ferrous materials such as Aluminium. The machine is programmed and controlled via a suite of software that is supplied with the machine. Although all the programming is done graphically the machine itself is driven by conventional G-Code (Word Address) programs. The program is generated automatically by the Denford software and appears in a window during a program run. Normally there is no need to interact with this code and it is not dealt with further here.

Operation of the Machine

The machine is controlled via the **Denford Virtual Reality CNC Milling** software package. This software performs two functions:

1. It provides an interface for setting up and running the machine
2. It offers a virtual reality simulation of the machine with an identical interface to the real one and a realistic 3-D simulation of the working of the machine itself.

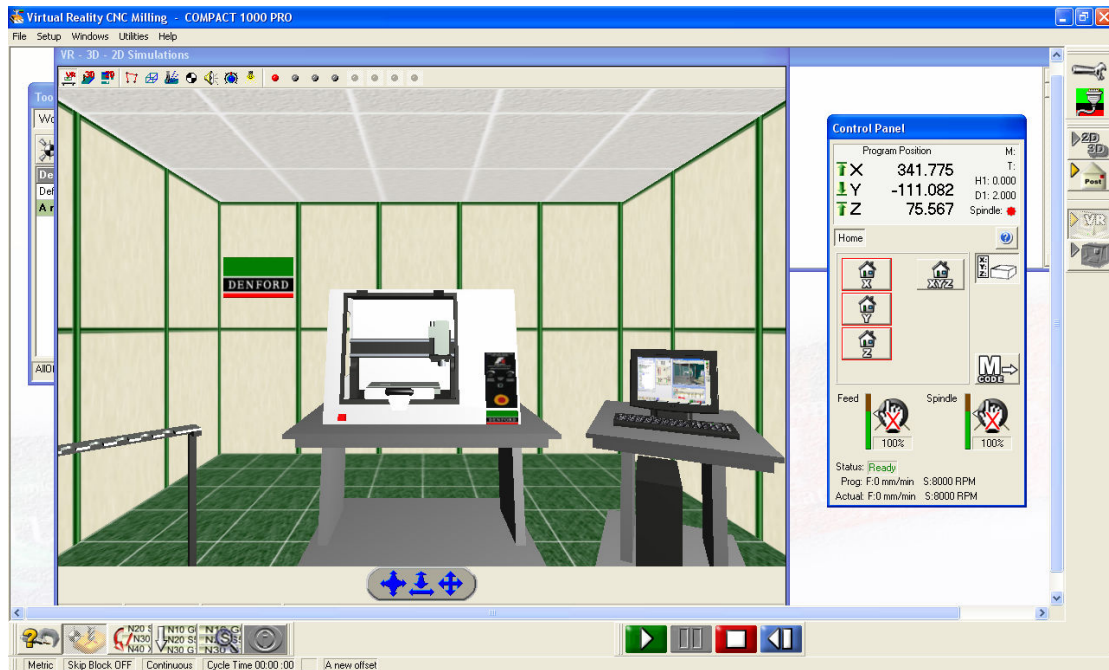

The control panel looks like this and contains an emergency stop button and overrides for the spindle speed and feed rate. All other functions are carried out using the VR milling software.



Figure 14 Control panel of Compact 1000 Pro

There are three main aspects to using the CNC routing machine. These are:

- Tool and datum setting
- Workholding and operation of the machine.
- Programming

Workholding

The table of the machine is made from Aluminium with Tee slots for clamping bolts like a conventional machine. The usual way of holding small parts is to use the sliding clamp system shown below.

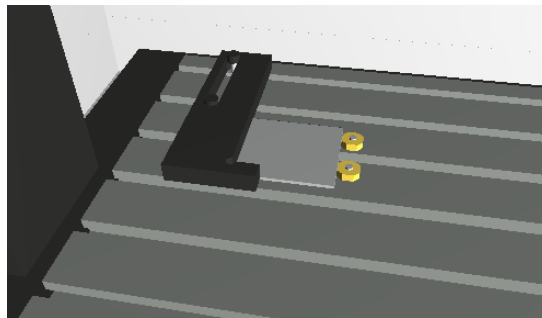

It is common to mount a block of stable material on the machine table to raise the work piece up from it. A typical block might measure 100mm square and have a height of 50mm. The work piece can then be fitted to the top surface of it using double sided tape. This is ideal for PCB manufacture and for the machining of acrylic. It also has the advantage of offering no obstacles for the tool to collide with during machining. The tape used is a special grade that peels cleanly from the work piece afterward. The double sided tape available in stationery shops leaves a residue that can be cleaned using a solvent such as paint thinners.

For workpieces that are not suitable for tape, they can be mounted on machine table using the clamp. However, more care must be taken to ensure that the tool does not interfere with the vice.

The datum for most operations will be the bottom left of the work piece as one looks in from the front of the machine. Setting the machine datum to this point is a relatively simple matter and is dealt with next.



Figure 15 View of the machine table

Preparing the Machine for Use

The machine offers a simple and user friendly means of setting up cutting tools. Before looking at this it is necessary to understand the issues involved.

Machine Datum Points

When first powered up, the machine needs to locate a homing point on the X, Y and Z axes. This provides an accurate and repeatable means of zeroing each of the axes and means that even if the machine is powered down, it will be able to resume work on a partly machined item. The machine zero point is located near the top right of the table for the X and Y axes and near the highest point of its travel for the Z.

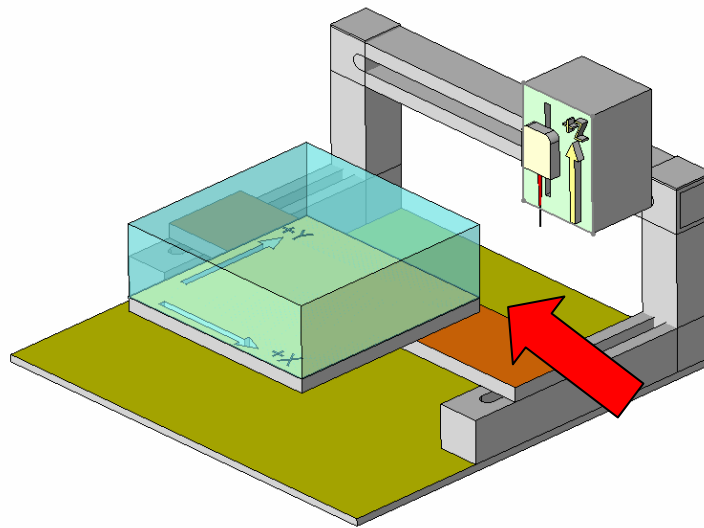

Figure 16 Machine Zero point

However the work piece datum is often on the top left corner of the blank as shown below and the program coordinates are measured from here.

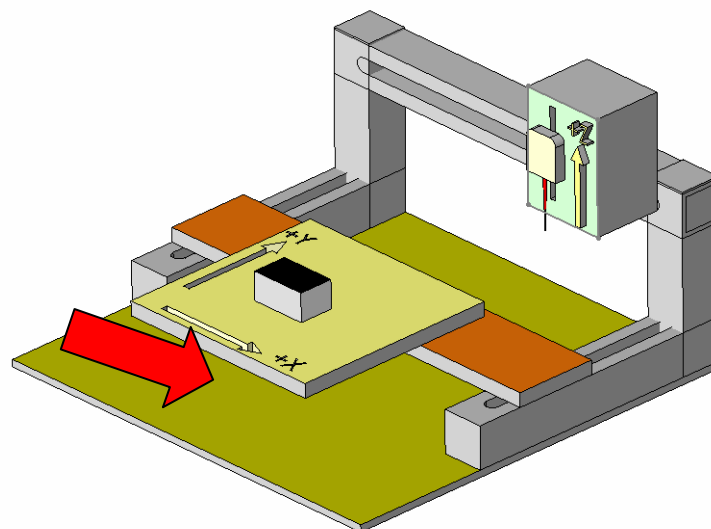

Figure 17 Work piece Datum

Setting this point as the datum for the machining is an important task and is dealt with in detail in **Appendix 1**.

Tool Length offsets

It is common to use the top of the work piece as the datum for the Z axis. i.e. $Z=0$ for the top surface of the billet.

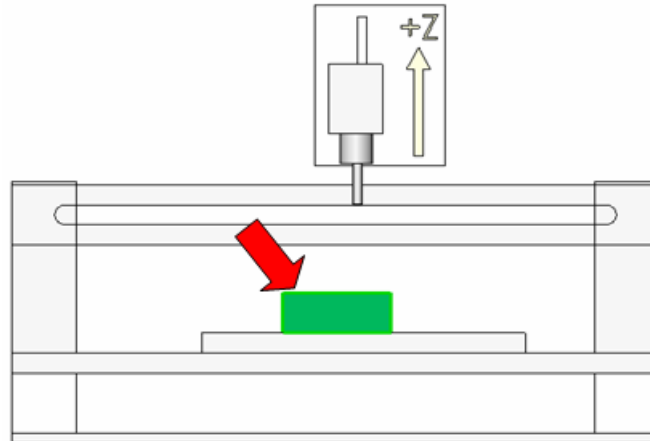

Figure 18 Location of the Z axis datum

This is obviously not the same as the machine zero. Furthermore, when a cutting tool is fitted, it will project down below the machine zero. The machine will have to compensate for the gap between the tool and work piece when calculating where to move.

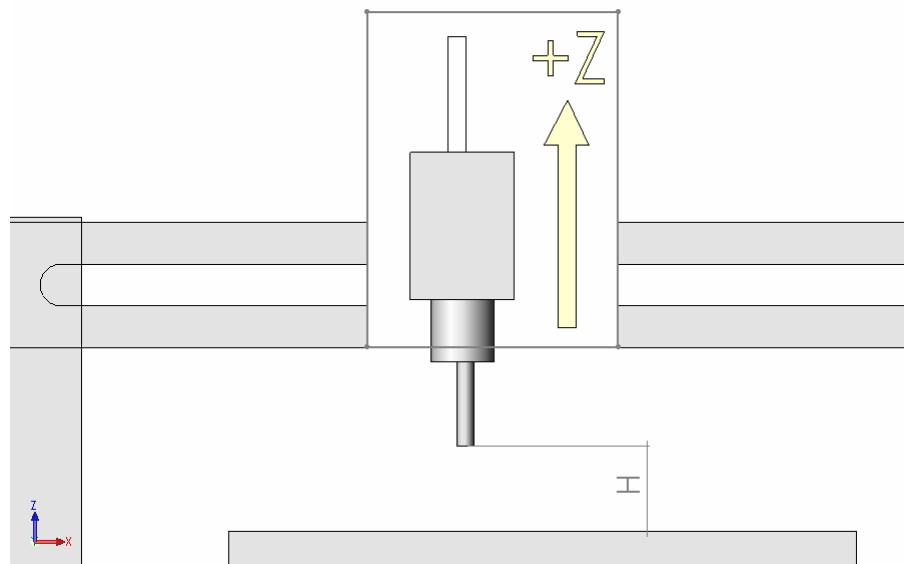

Figure 19 Gap between tool and work piece

This is further complicated when several tools (e.g. a roughing and a finishing tool) are used as they may have different lengths.

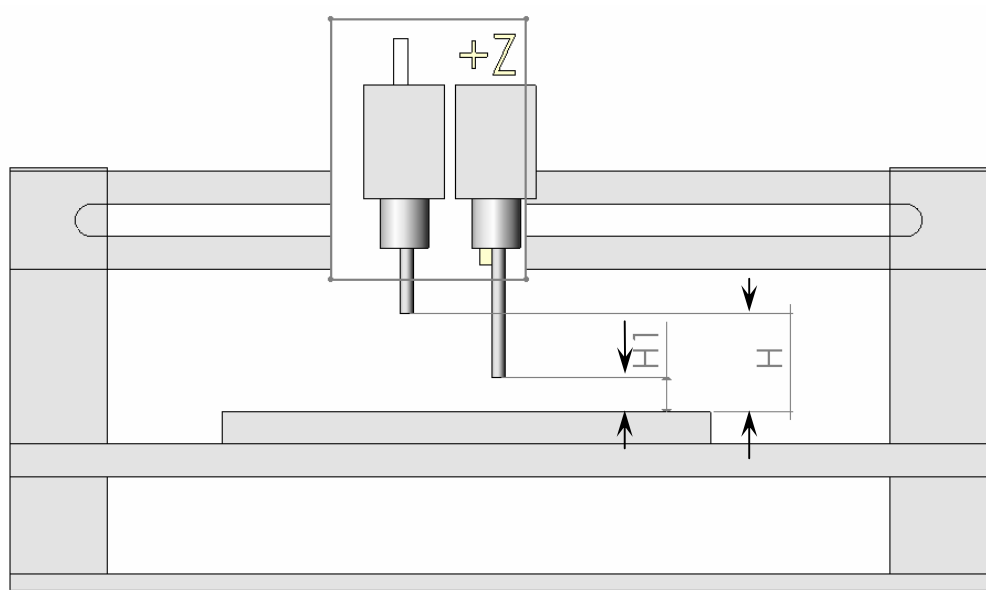

Figure 20 Tools of different lengths.

To compensate for this, each tool will need to have its height set before it is used. In practice this process is made a little simpler by using only one tool per program and using two or more programs if necessary.

2-D Machining

General Issues relating to 2-D machining

The following points apply to 2-D machining across all applications. This type of part consists of one or more profiles, each machined at a constant depth. Clearly a two dimensional drawing of a single profile cannot represent the part completely and information regarding where to cut and how deep needs to be added. As well as this, heights for clearance moves between profiles, speeds and feeds need to be entered also. Taking this into account, a 'simple' 2-D part will often be more complex to set up than a 3-D one. Machine manufacturers tend to each take their own approach to addressing these issues. The following section deals with the QuickCAM system only.

Main Considerations in Setting-up a 2-D Part

Consider the desk tidy project shown below:

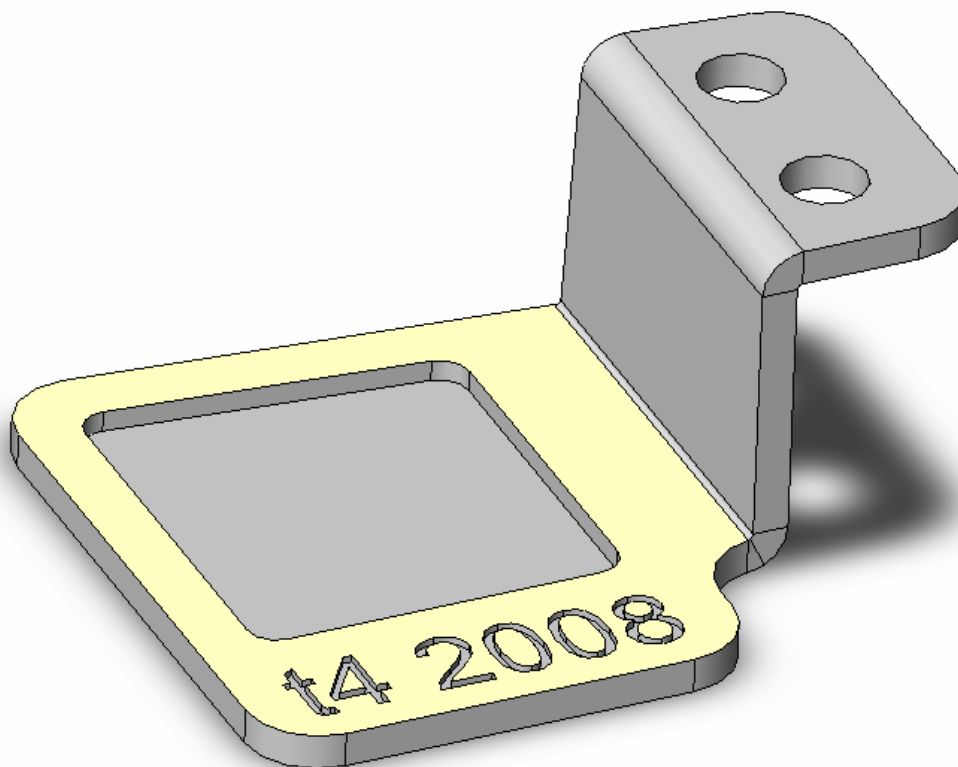

Figure 21 Desk Tidy project

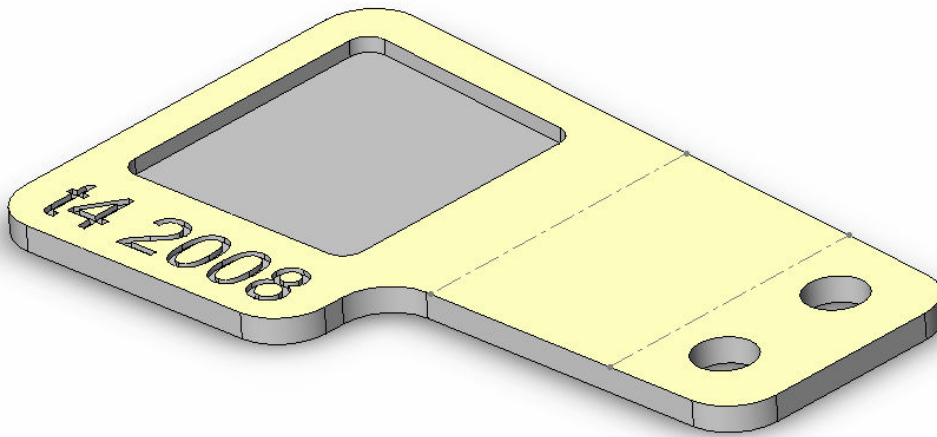

Figure 22 Desk Tidy before bending

Note that the roughing toolpath has been omitted for clarity in this example.

In order to produce the part accurately the tool must cut to the correct side of the profile as shown below. To do this, the diameter of the tool must be known beforehand. It must also move clear of the work piece when moving from one profile to another and move to the correct depth of cut afterwards. In addition, the area inside the pocket must be machined away to the correct depth.

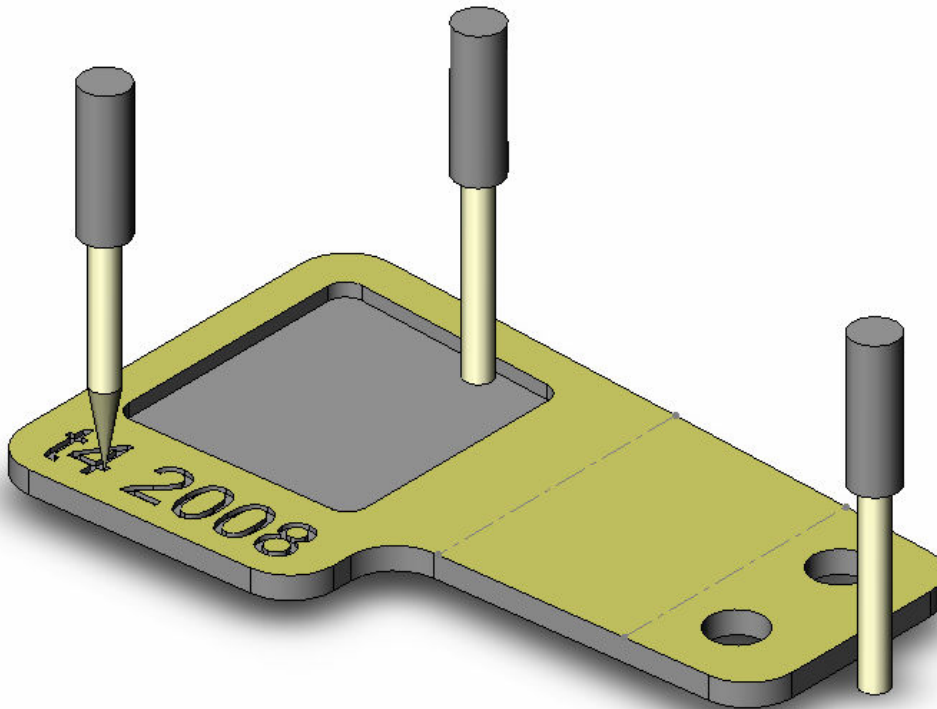

Figure 23 2-D profile showing tools and offsets

This is done on the Denford machine using a **Machining Plan** for each of the contours. A machining plan allows the speed, feed, depth, direction of cut and offset to be defined for each profile. There are also machining plans for pocket milling and drilling holes.

2-D Machining on the Denford Compact Pro 1000

QuickCAM 2D is used for drawing up and creating programs for 2-D profiled parts. It offers a limited CAD-like drawing environment with basic functionality. It also allows the setting up of machining plans as described above. There is a comprehensive user manual outlining the functions of all the drawing and editing tools. 2D Design is adequate for simple shapes. For more complex designs it may be easier to use a CAD system such as SolidWorks and then import the drawing into 2D Design for machining.

The issue of file transfer between different software systems has been discussed earlier.

The issues relating to setting up cutting tools and machine datum's are dealt with in **Appendix 1**. It is recommended to read this before moving on to the next section.

The detail of running a program on the machine and machining the part are explained in **Appendix 2**.

2-D Machining Exercise

The aim of the exercise is to produce the name plate shown below.

First, a partly complete drawing will be imported into 2D Design. Then further geometry will be added to it before creating toolpath and machining it.

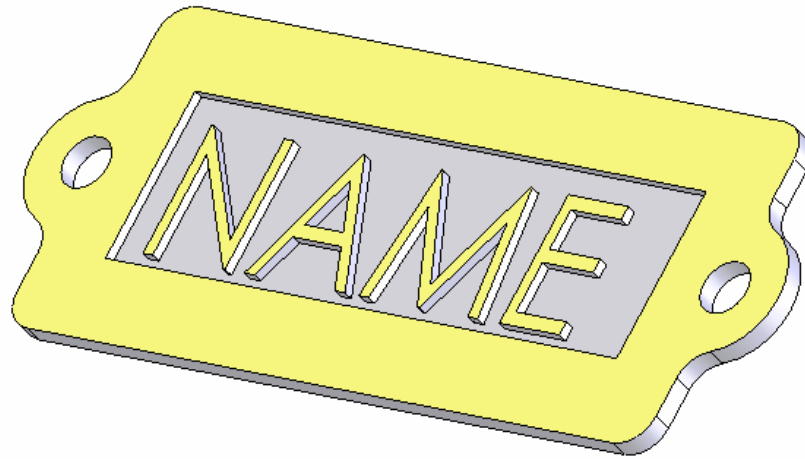
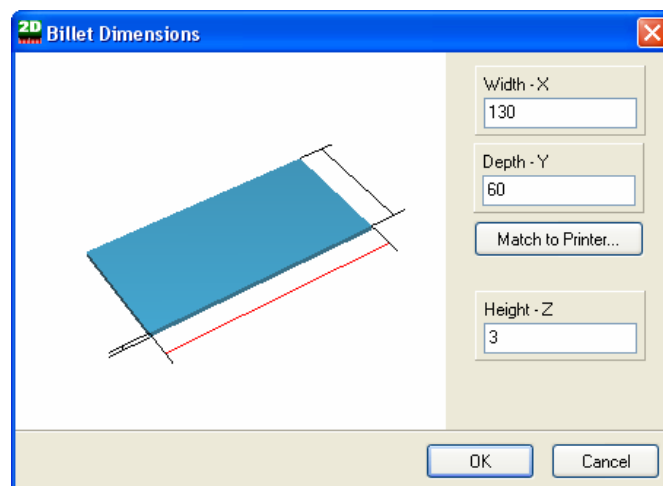

Figure 24 Name Plate Project

Start QuickCAM 2D and do the following before starting the exercise:

1. Set the billet size to the dimensions shown below:



2. Select **Options – Grid** and set the grid size to 5mm. Make sure that **Show Grid** and **Snap to Grid** are turned on.

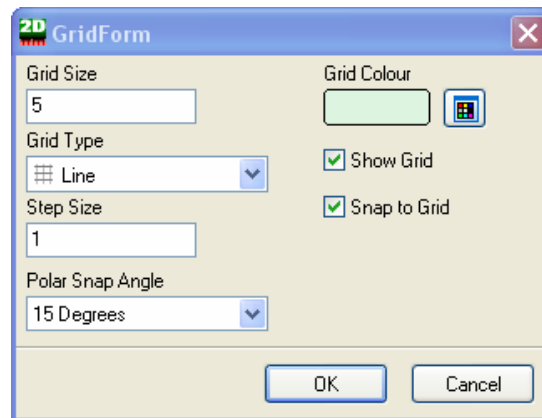

Next, Select **File – Import** and choose the file **NamePlate.DXF**. This file contains the geometry for the outer profile of the sign. It was created in Solidworks and exported in DXF format. The profile will automatically be moved as close as possible to the bottom left of the billet as shown.

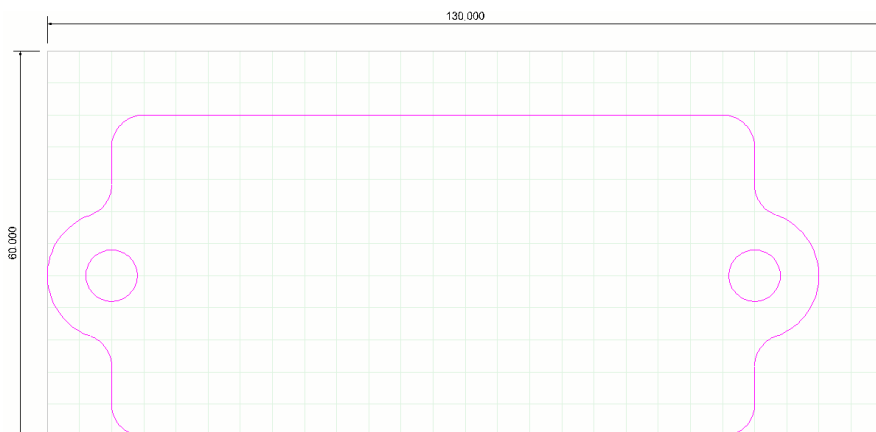

The profile should now be moved so that it is not touching the edge of the billet. This will make the setup easier later on and will ensure that all edges are machined and clean up properly. The profile should be highlighted in pink as shown above. If not, drag a box around it to select it. Next select the '**Alter Selected**' Button to move the profile.

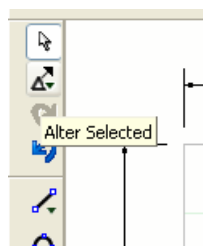

The profile can now be dragged into position as shown below.

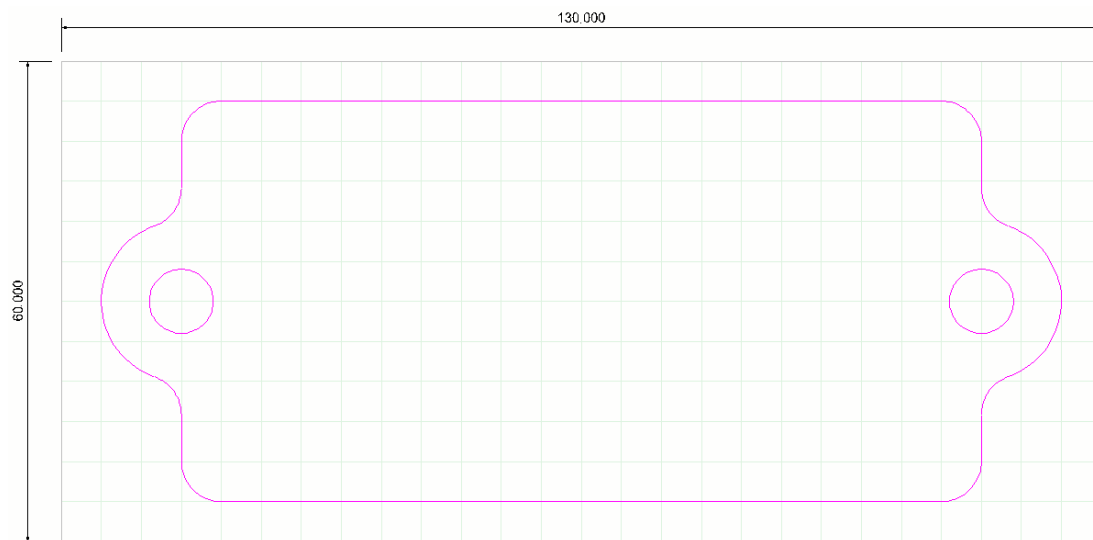

The next task will be to add a rectangle and then put some text into it. Select the **Add Shape** button to start drawing a rectangle

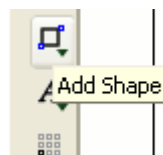

Use the snap and grid to create a rectangle 80mm long and 30mm high like that shown below.

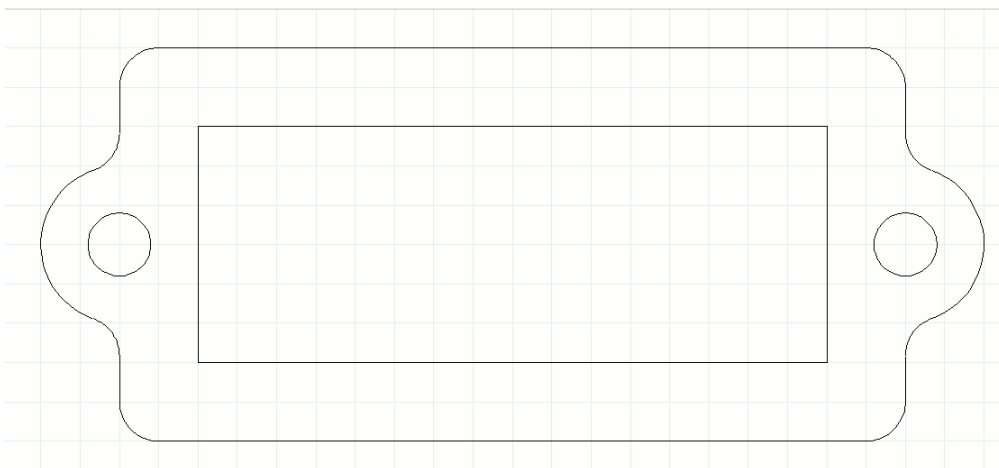

Select the **Text** button on the left toolbar and drag a rectangle to place the text inside the rectangle you have just drawn. Leave one grid increment between the text and the boundary as shown.



Now the following dialogue will appear:

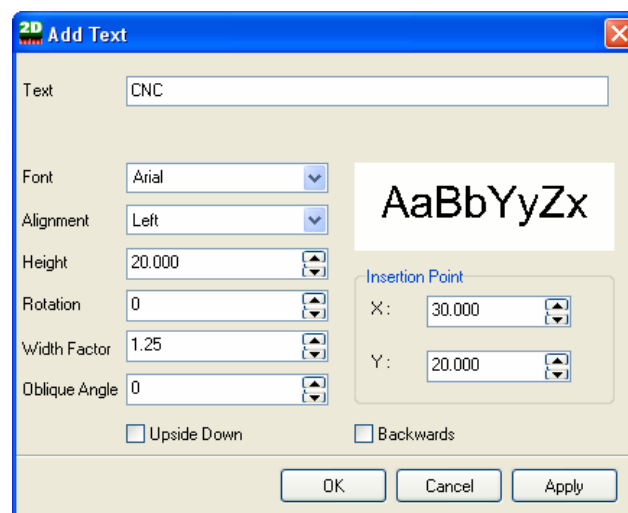

In this example, the **Arial** font chosen will give 'Thick' letters that can be left as islands in a pocket. An alternative would be to choose a font such as *Simplex* that could be engraved directly onto the surface of the work piece. Note that the width factor has been set to 1.25. This provides additional space between the characters and so allows a larger tool to be used for the machining.

Select **OK** and the text should appear as follows:

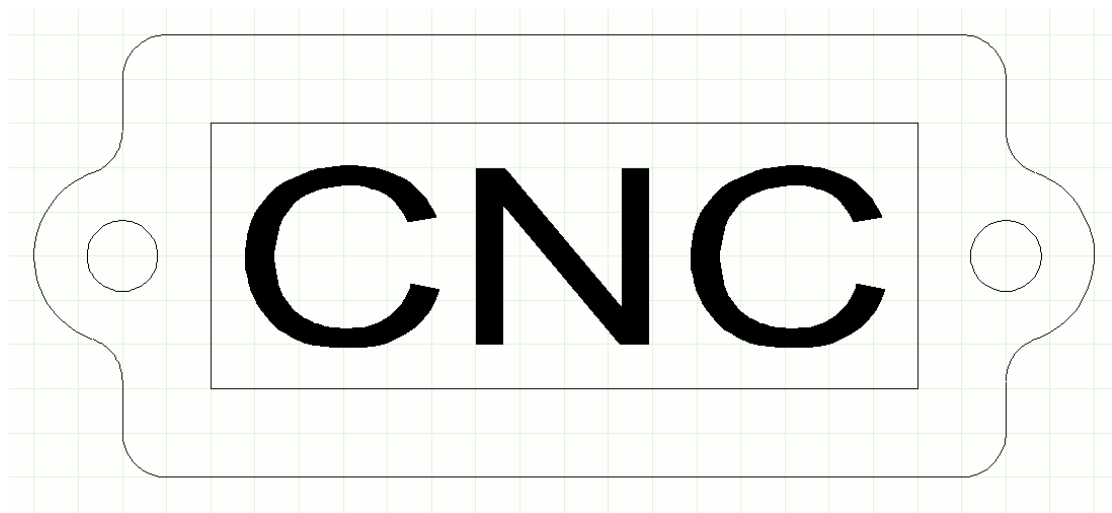

If the text is not evenly placed in the box, turn off the **Snap to grid** option using the button on the menubar at the top of the screen and use the move command to place it on centre.

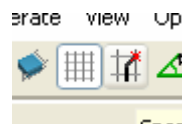

This completes the creation of the geometry.

The next step is to create *machining plans* for the profiles and to generate the program.

Creating Toolpaths and Machining Plans

All aspects of the machining of the part are dealt with by the CAM Wizard. It can be run by clicking on the button on the top toolbar.

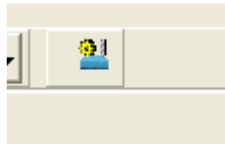

The first step in the Wizard is to choose the material being cut. Each material has machining parameters such as speed and feed associated with it.

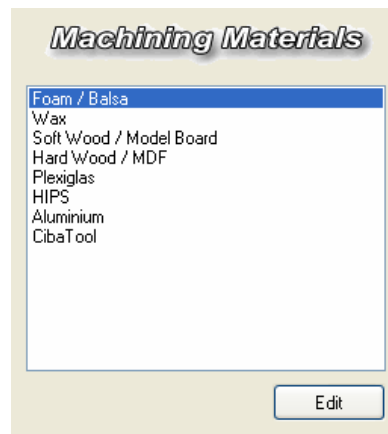

Click on **Edit** to see the details of each material. Exit the list and select HIPS (High Impact Polystyrene) from the list of materials before proceeding onto the next step.

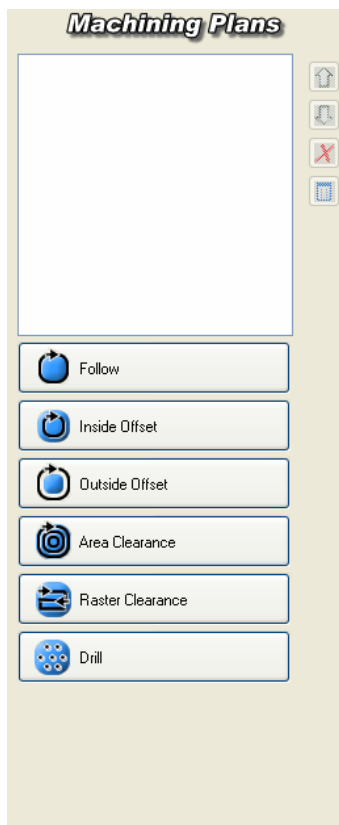

In this step a machining plan is assigned to each of the features to be machined.

When first run the window containing the plans is blank.

The types of plan available are at the bottom and are self explanatory

First, a plan will be created for the outer profile. The

tool will need to be offset to the outside and the depth of cut will be 3mm.

Create an **Outside Offset** plan and choose the 2.5mm Slot Drill and set the depth of cut to 3mm as shown below.

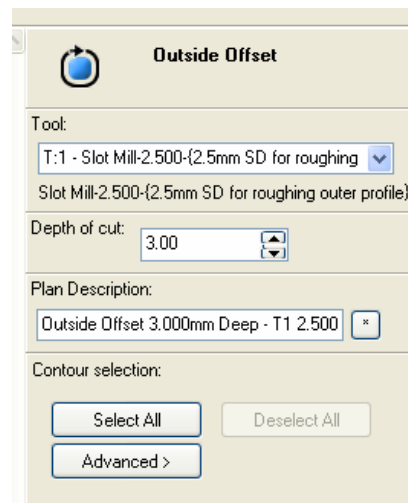

Next, select the outer profile of the part – It will become highlighted in green – and then select **Apply**. The toolpath will be created for the centreline of the tool as shown below in blue.

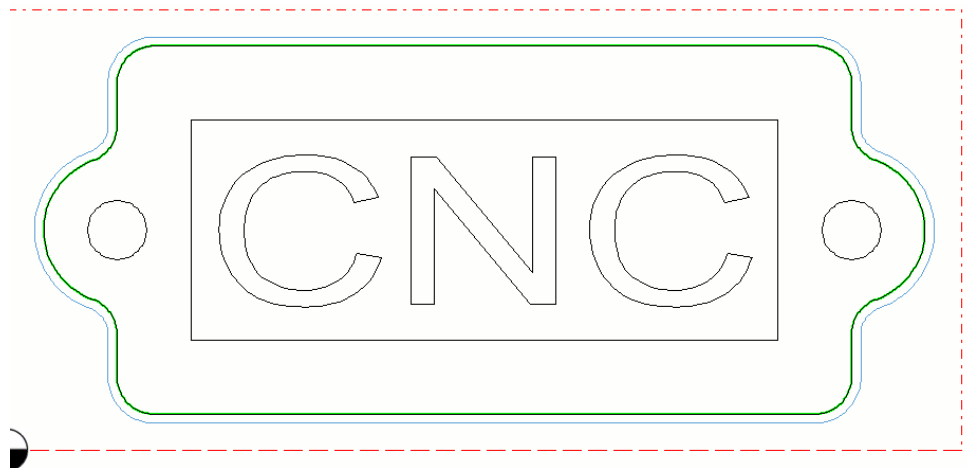

The machining plan for the operation will now be added to the list:

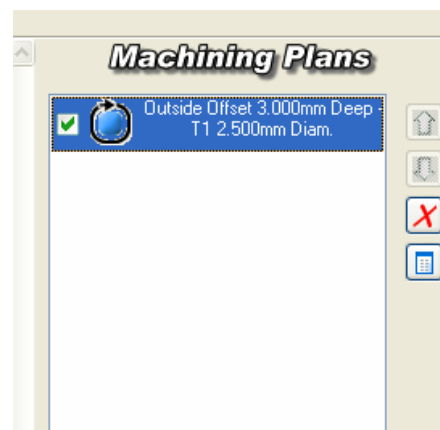

Now, create an **Inside Offset** plan to machine the two holes on the part before moving on to machining the text. The object is to machine out the pocket defined by the rectangle while leaving the letters behind as islands. The pocket will be machined 1.5mm deep. To do this, proceed as follows.

Select the **Area Clearance** plan and set the tool and depth of cut as shown below.

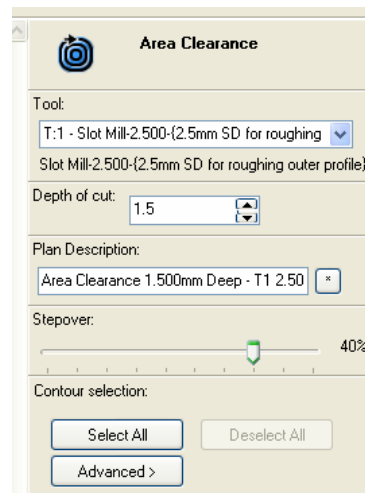

Next, select the rectangular pocket and all the entities inside it. This is easiest done by dragging a window around them.

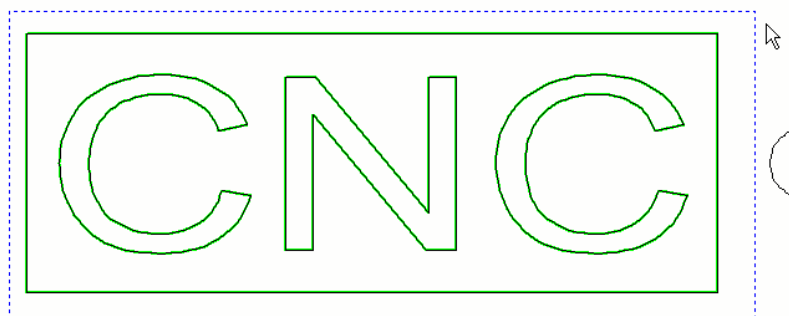

QuickCAM will recognise the profiles within the rectangle as islands and will avoid them when generating the area clearance toolpath.

The result should look like that below.

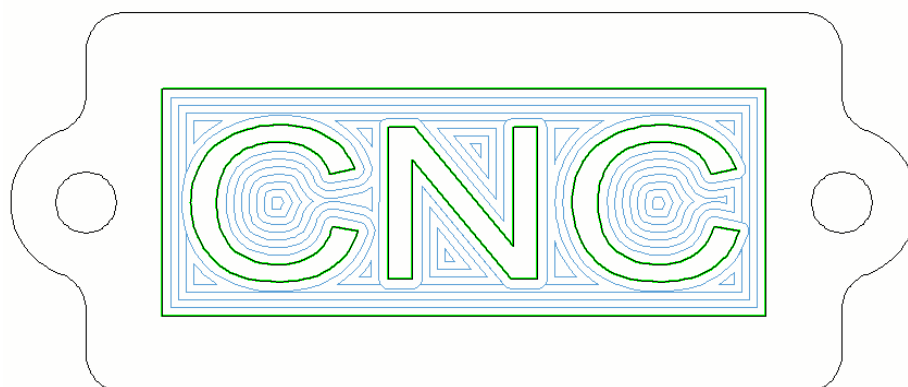

Reordering the Sequence of the Operations

Looking at the list of machining plans in the window, they appear in the order that they were created in. This is the order they will follow when machining on the CNC.

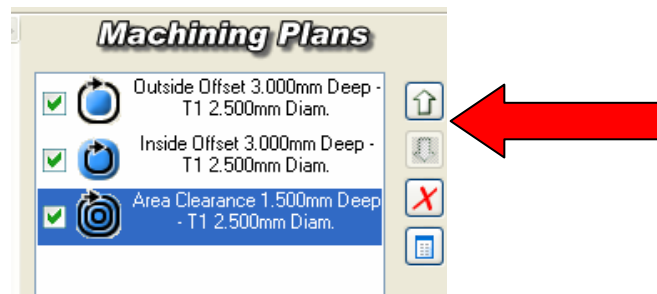

In this example it would be desirable to have the outside profile cut last to ensure maximum grip to the machine table. The arrows on the right hand side of the window allow the machining plans to be moved up or down the list to change their order.

Use the arrows to change the sequence to that below.



Now that the toolpaths have been created, the next step is to verify them and generate a program. Select **Next** to move on to the final stage of the process.

In the final Post Process stage, the toolpath created in the previous step is used to generate a CNC program that is sent to the machine. The machine type should be set to **Denford (metric) Milling** and the default File name **Untitled.fnc** can be left as is.

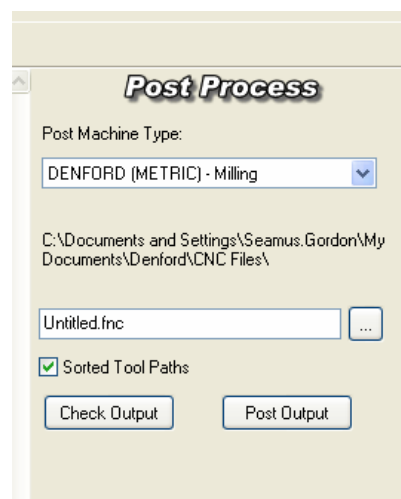

If the **Check Output** button is clicked a simulation of the tool moves will be shown. Notice the rapid moves are shown in green. This step is useful for checking that none of the profiles have been forgotten in the previous stage.

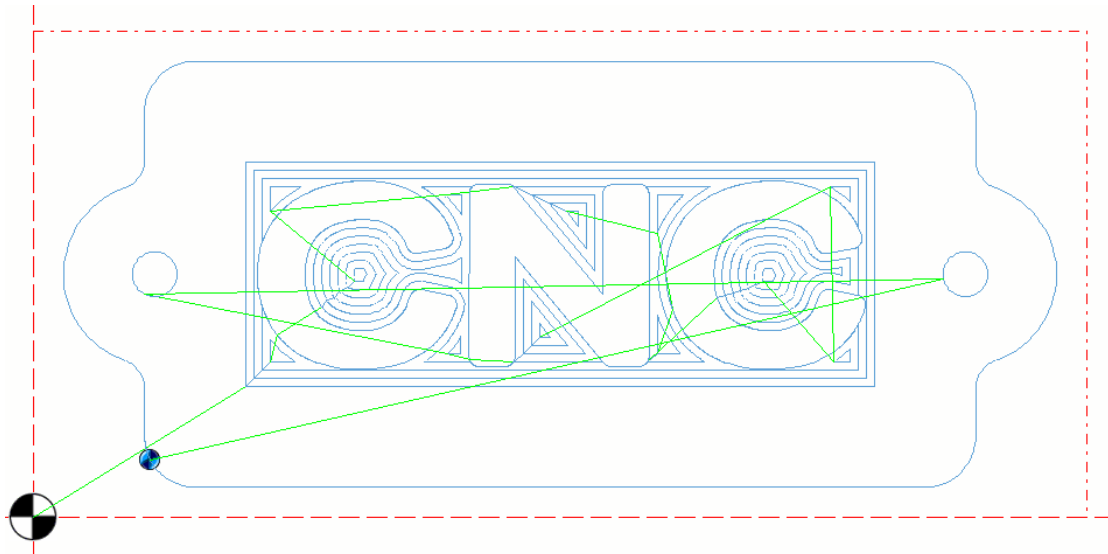

Once happy, click on **Post Output** to generate the program.

This will generate the program and will open it in VR Milling for the next stage of the process.

Working with VR Milling

When the Post Output option is selected in QuickCAM, two things happen:

- The program is generated
- Virtual Reality Machining is started up and the newly generated program loaded into it.

It is important to be aware that you are no longer in QuickCAM but are instead in the machine interface / simulation environment. QuickCAM still remains running in the background and any changes to the program will require getting back into it and repeating some or all of the operations described in the last section before re-generating a new program.

When it is first run up, VR milling will look like the following:

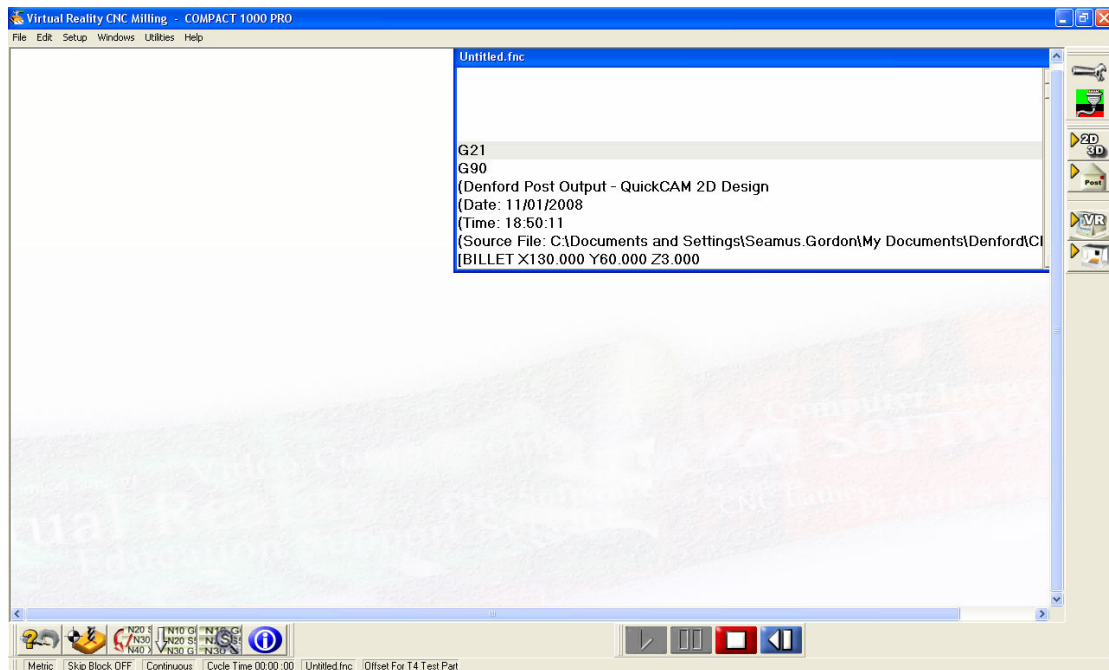

The display area is empty except for a window containing the program just generated. On the right are a number of options that control the display. These can be switched on or off as required.

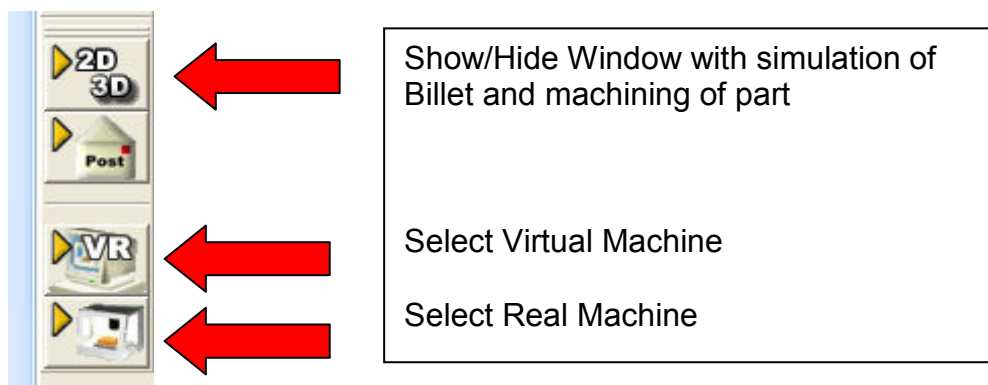

To simulate the program, select the 2D/3D button to display the simulation window.

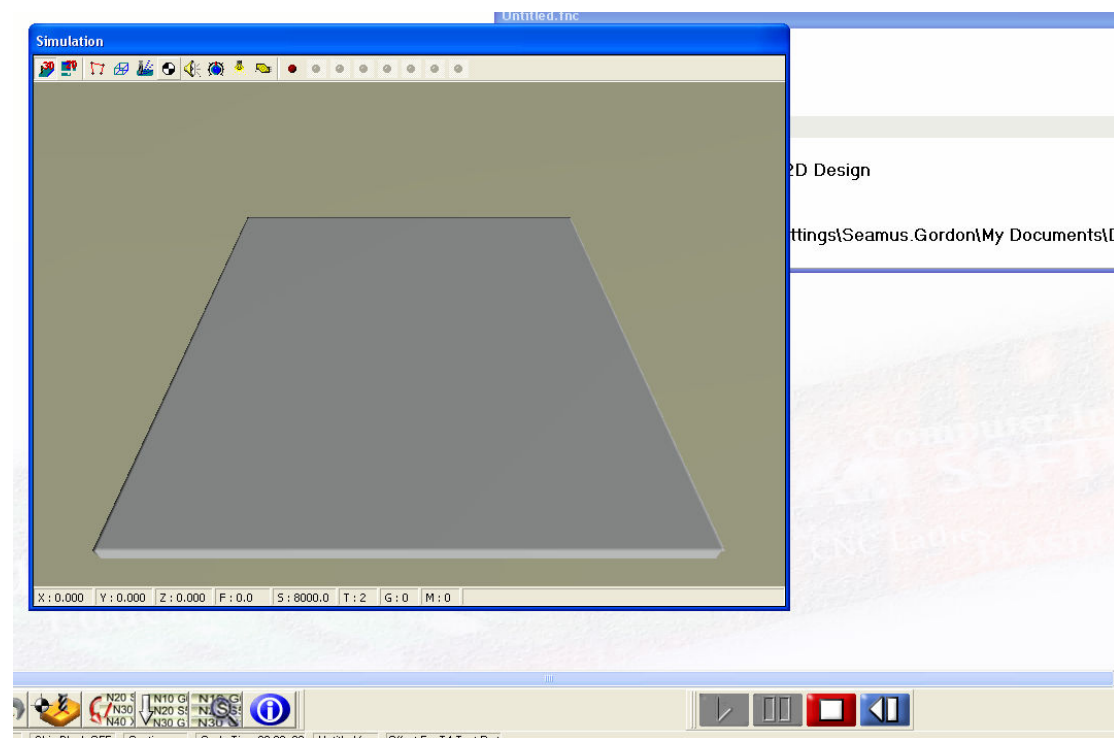

Notice the four buttons on the bottom right of the screen. They behave like the real machine, even requiring a program rewind before being able to run the program. Rewind the program using the blue button. This will enable the green **Run** button on the left.

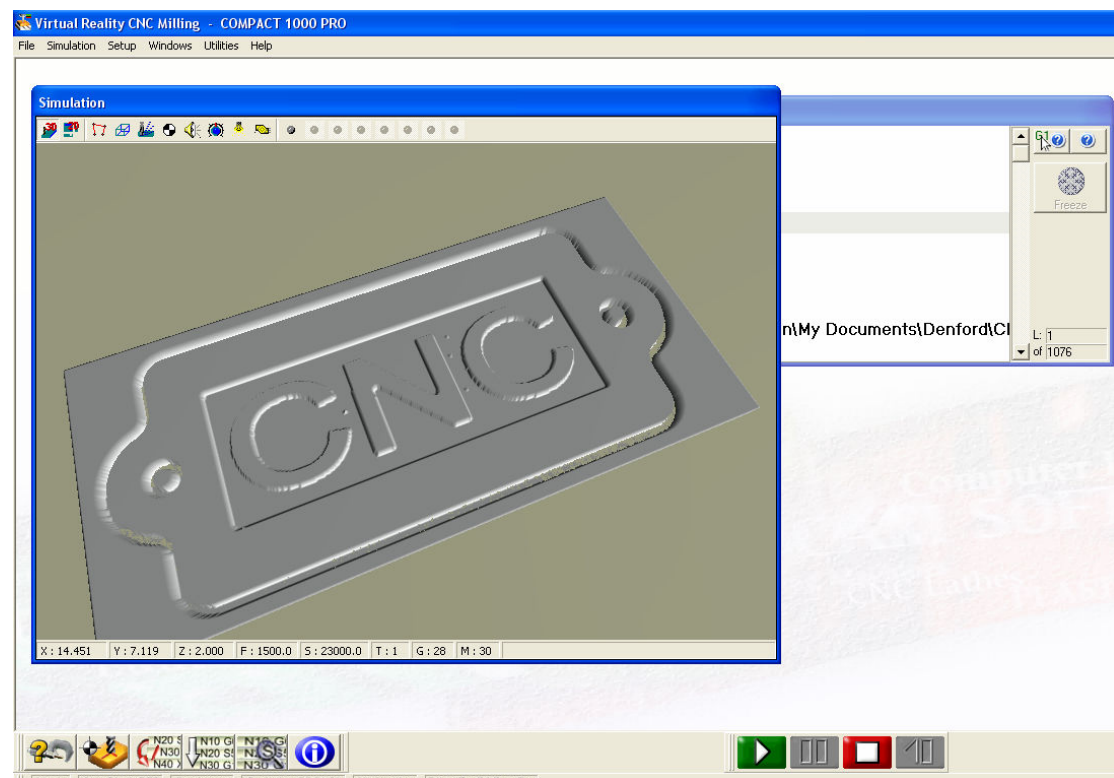

Cutting the Part on the Machine

Fitting a cutting tool to the machine

The machine uses a standard collet chuck similar to those used in industrial routers.

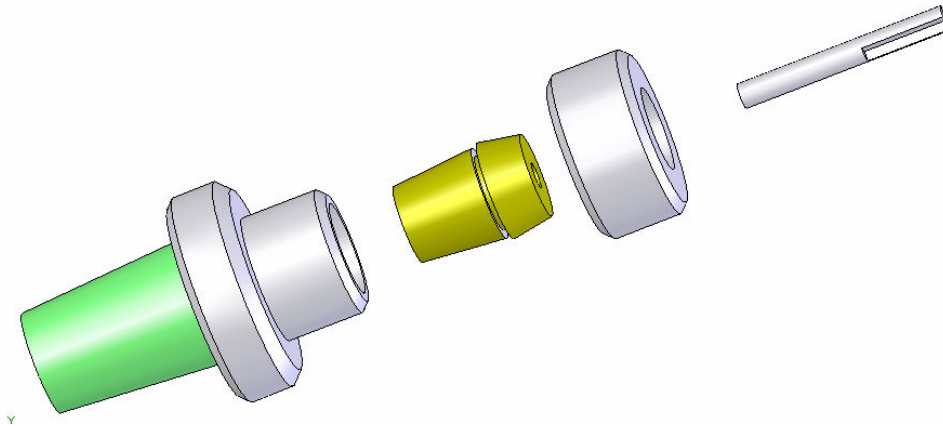

When fitting a new tool, always make sure to fit the collet to the nut first. There is a retaining ring inside the nut that engages with the undercut in the collet. The collet should engage in this with a click. The tool can then be fitted to the collet and only then should the assembly be screwed into the machine arbor.

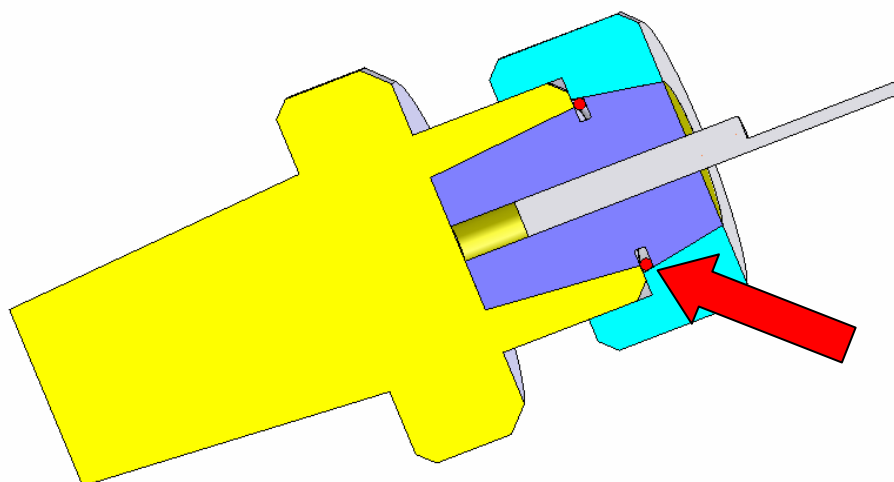

When the nut is next removed, the retaining ring pulls the collet free of the machine arbor thus releasing it. If the collet is not engaged with the nut, the nut will simply come off leaving the collet tightly stuck in the arbour. Removal will invariably require force or impact which will likely damage both the collet and machine over time.

Running a program

To run the program on the machine, hide the 2D/3D simulation window and select the **Real Machine** option instead. The program is run in exactly the same manner.

To increase the speed and fluidity of the movement of the tool set Turbo Mode to on before running the program. Otherwise, the program will be run one line at a time. Where many small moves are involved (such as the case here) there will be a noticeable difference as the tool comes to a stop at the end of each move.

MAKE SURE THAT THE CORRECT TOOL IS FITTED AND THE CORRECT OFFSETS ARE ENABLED AS DESCRIBED IN APPENDIX 1. OTHERWISE THE TOOL MAY COLLIDE WITH THE WORKPIECE OR MACHINE TABLE CAUSING DAMAGE.

Projects

- Redesign the name plate so that the rectangle stands proud of the top surface and the text is machined into it using a single line font such as **Simplex**
- Design and make a noughts and crosses game.
- Design and make the square/triangle/circle game.

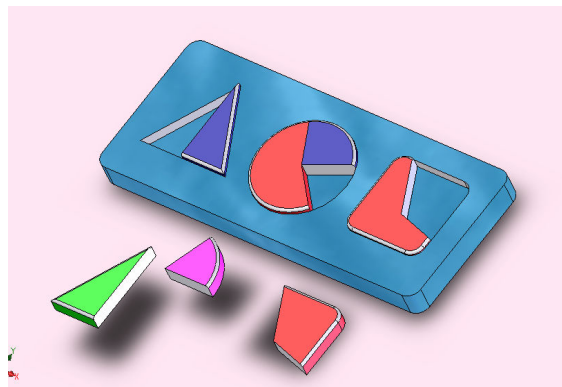

PCB Manufacture

PCB manufacture is quick and easy using the Denford Compact 100 Pro. PCBs are made from a material known as 'copper clad board' that consists of a paper based laminate material covered on one side with a thin film of copper. The technical name for this material is FR2. The copper can be engraved away to form tracks that make up the circuit on PCB. The production of a PCB involves up to three operations.

- The first is to engrave the tracks and pads using a vee engraving tool.
- Once the tracks are complete, holes can be drilled in the pads to allow the wires from the components to pass through.
- The third operation is to cut the outline of the PCB to size.

The last two of these operations are optional and the drilling can be done by hand later if the holes are centre spotted with the engraving tool at the time of machining.

A vee engraving tool typically makes a cut of about 0.3mm wide when cutting at 0.25mm deep. This needs to be taken into account when designing a PCB and enough space needs to be left between adjacent tracks to allow the tool to pass between them. If the tracks or pads are made too close together then all of the surrounding copper may not be removed. Adjustments to the PCB are best made using the PCB design software (PCB Wizard, Circuit Wizard or similar) beforehand.

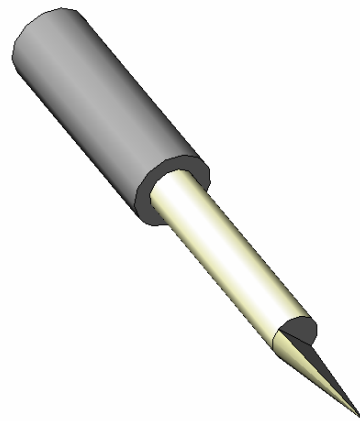

When designing a PCB it is a good idea to make the tracks and pads and isolation gaps as large as the size of the PCB will allow. This makes soldering easier and reduces the chance of over soldering and short circuits. The diagrams below show the same circuit. The PCB on the left has increased track and isolation gap widths.

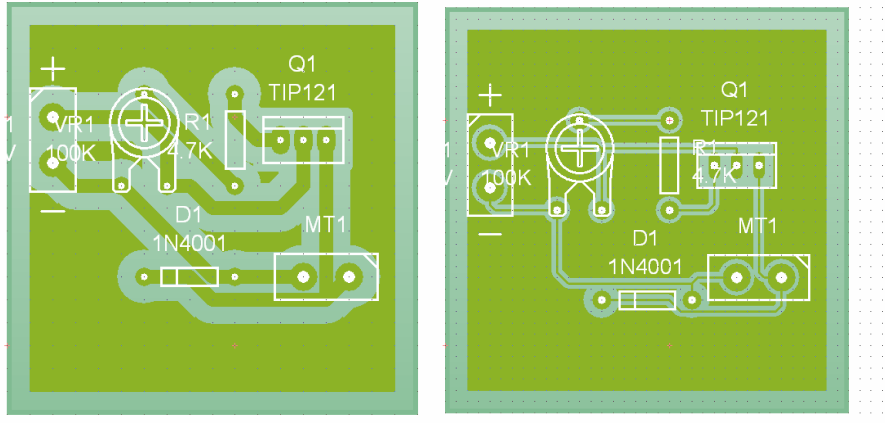

The parameters governing the characteristics of the PCB are chosen as options within Circuit Wizard during the conversion from circuit diagram to PCB.

The soldering of the PCB can be further simplified by machining away all of the remaining copper from the board and leaving just the tracks. However boards made this way take much longer to machine so there is a tradeoff involved.

Drilling Holes on a PCB

There are a number of options for drilling the holes on a PCB. Holes are recognised automatically and can be either spotted using the vee tool for hand drilling later or else drilled on the router as a separate operation. If this option is selected, then a tool change will be needed. This will involve setting up the drill in the machine in the middle of the PCB production operation and is probably not justified unless a large number of boards are being produced as a batch.

Manufacturing a PCB using the Denford Router

Rather oddly, PCBs are produced on the Denford system not by any of the QuickCAM packages but by a wizard within VR Milling. The PCBs are imported into the system as Gerber files. It is necessary to understand a little about the way Gerber files organise data in order to identify what to import.

As described earlier, Gerber files are a legacy from a time when PCB artwork was created using photoplotting devices made by the Gerber company. A PCB is composed of a number of layers i.e. Solder side, Artwork, Drill holes etc.

Each layer would have been separated out into a single file and plotted separately on the machine.

For this reason, when a PCB is exported to Gerber format, a number of files are created, each containing a specific aspect of the PCB. In this case the layers of interest are the Solder Side and the Drill Holes. These are often given the extensions .GB1 and .DRL respectively.

However some systems combine all of the Gerber files into one large file containing all the data on the PCB. Systems that read in Gerber files need to be able to cater for both.

Designing and Manufacturing a PCB

The Circuit shown below is for speed control of a motor. This exercise will involve creating a PCB for it and then exporting and manufacturing it. First start Circuit Wizard and load the file: **Motor Speed Control.cwz**

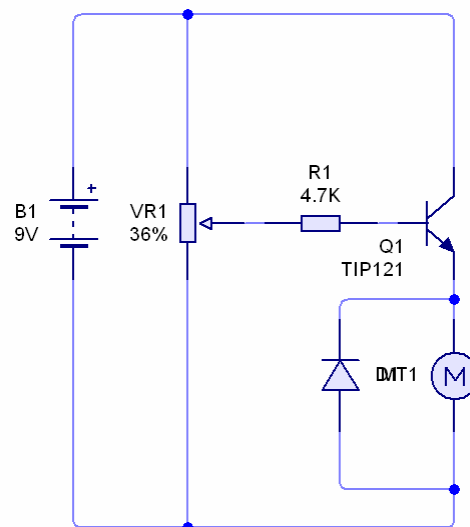

Creating a PCB

Start the process of converting the circuit by clicking on the icon at the top right of the toolbar.

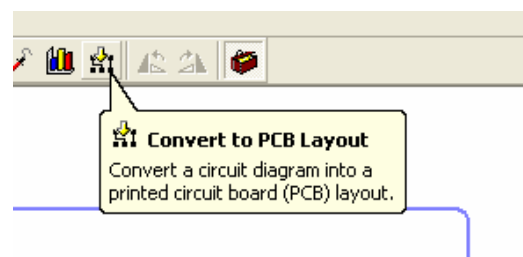

Click Next and select the 'Single Sided Thick Tracks' option as shown below.

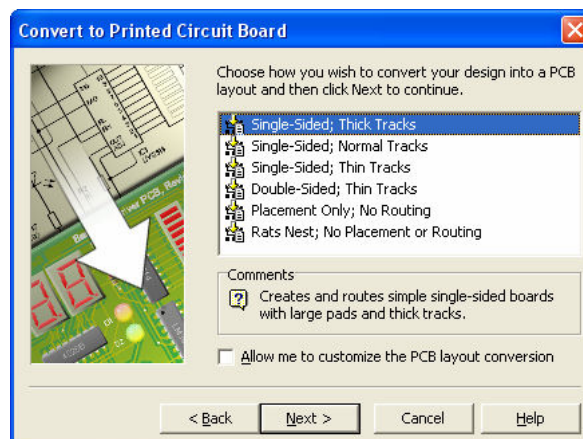

Accept the defaults for all the following dialogues until the conversion is complete. The PCB should now look like that shown below:

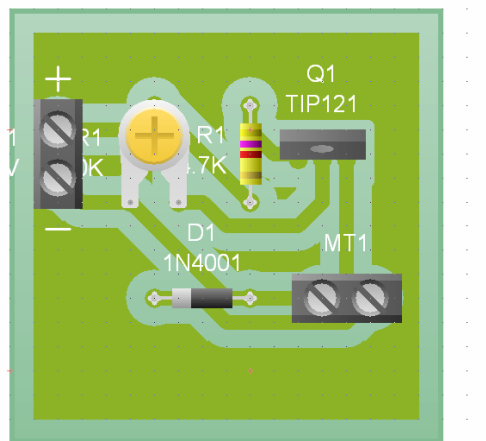

The PCB is now ready for manufacture. However if desired the placement of the components and track widths etc can still be changed if desired.

First make sure that Interactive Routing is enabled.

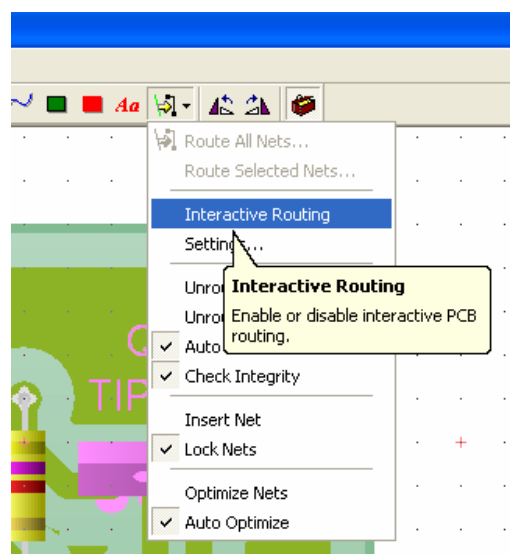

Now drag and rotate any of the components to a different position on the PCB (note the rotate icons are the two visible above the pull down menu in the figure above). It should be possible to position the components so that their layout on the PCB is similar to the circuit diagram. Make sure that there is adequate space between the tracks and pads for the cutter to pass between them. If not, reposition them until a satisfactory result is achieved.

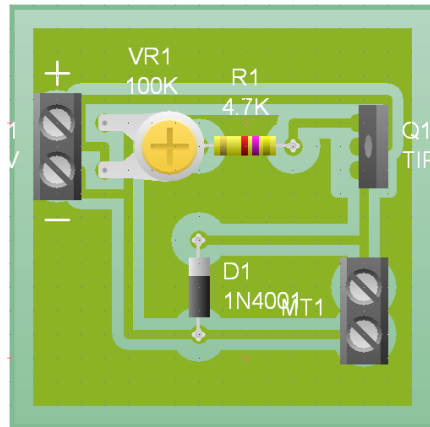

Save the file once you are happy with the layout.

Individual tracks can be moved by clicking and dragging on the nodes at the end of each segment. The width of a track can be changed by right clicking on it and altering the properties.

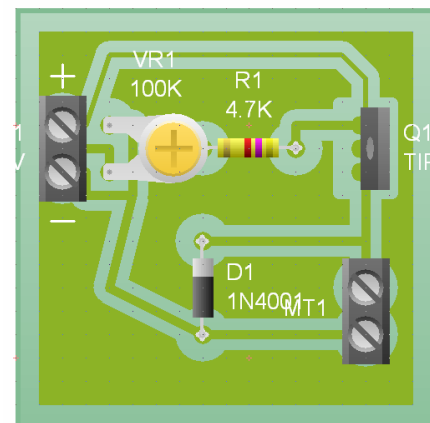

Note that intervention such as this is usually not necessary with simple designs such as this one but it will sometimes be necessary to reduce the width of a track to pass underneath an IC or to re-route it around an obstacle on the PCB with more complex designs.

Use **Undo** if necessary to revert to the correct design before proceeding to next section.

Importing the Data from Circuit Wizard to VR Milling

Transferring the data between the two systems requires the PCB to be exported in Gerber format from Circuit Wizard. To reduce clutter later on, delete the copper area on the PCB before exporting so that it looks like this:

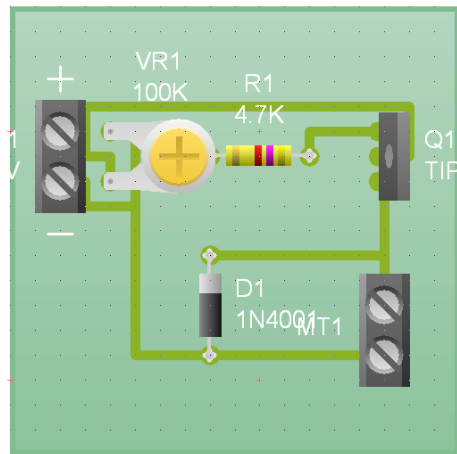

Select **File – CAD/CAM – Export Gerber**.

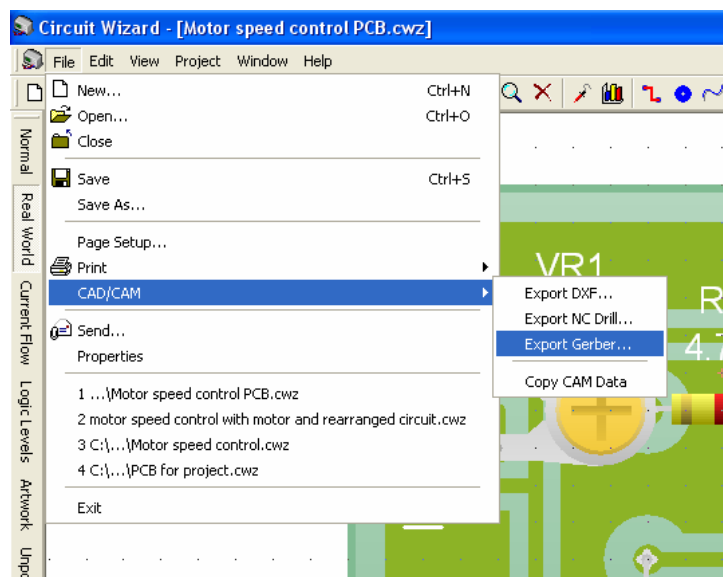

Choose a filename and make sure that the Solder Side is checked for export.

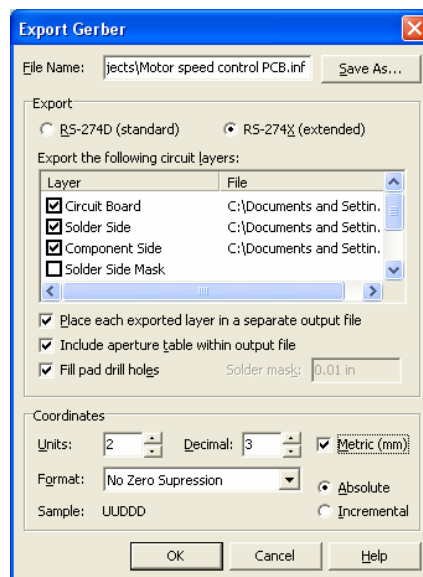

Select OK to create the files and exit Circuit Wizard.

Machining the PCB

Next, Start VR Milling

As there is no file loaded, the windows will all appear blank.

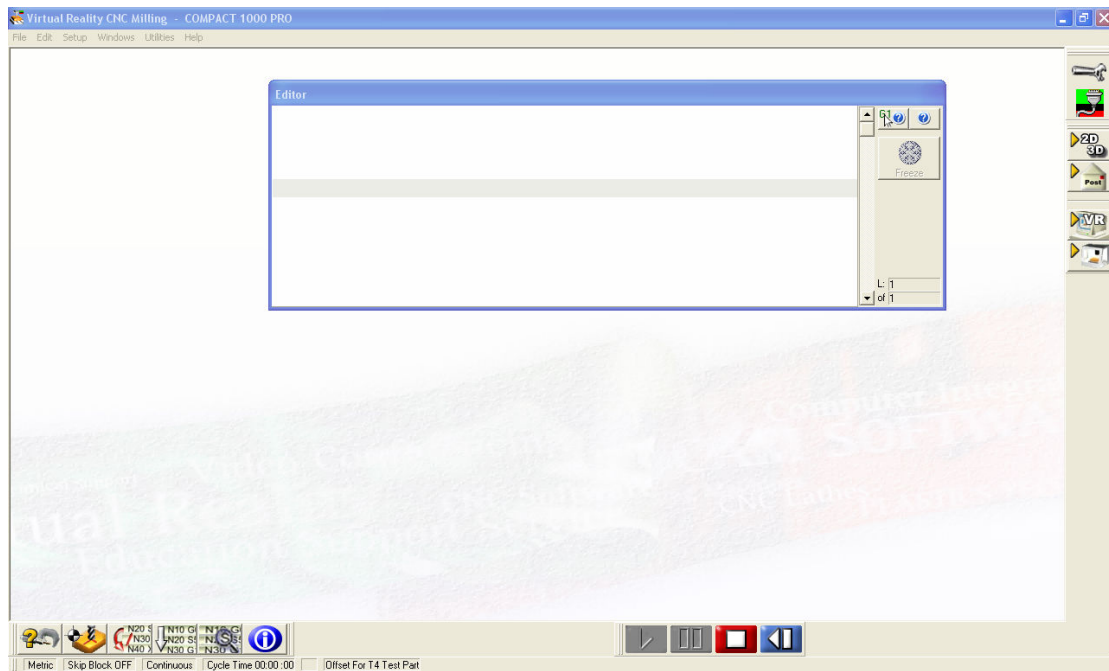

Select File – Open

Set the file type to Gerber (.gb*) and select the **.gb1** file from the list of files you just created.

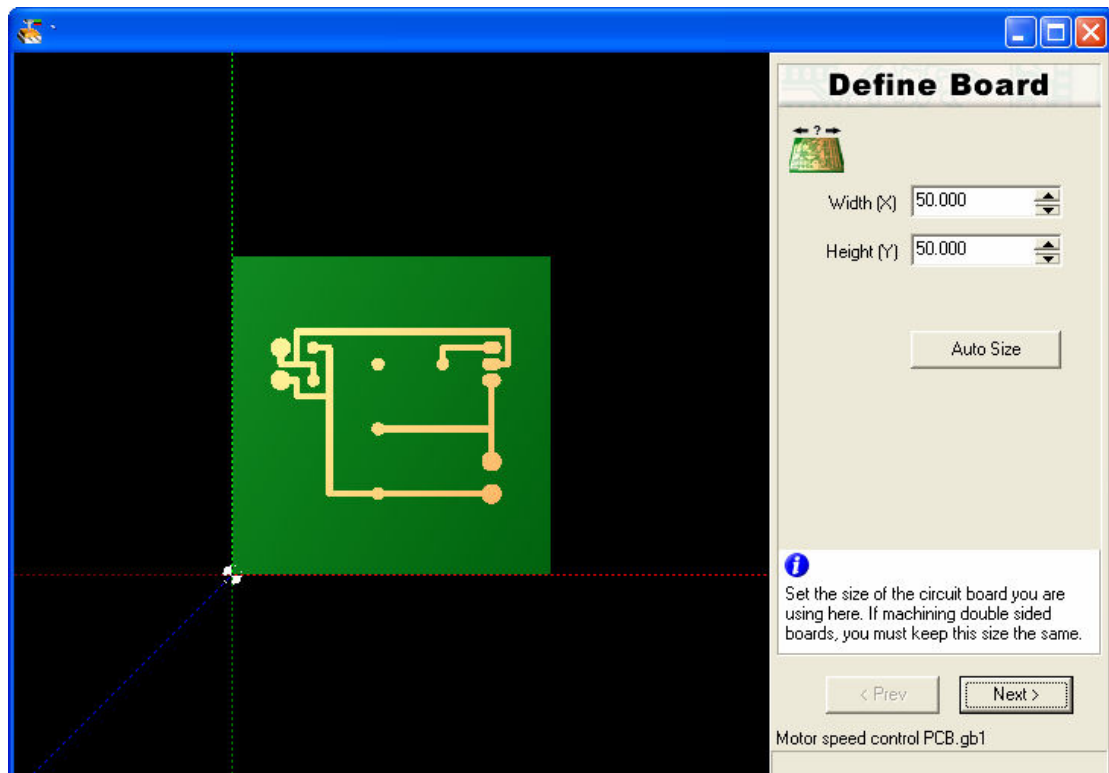

Set the board size to suit the PCB. 50mm x 50mm is a suitable size for this PCB. **Note** that it is not possible to move or reposition the tracks once they are imported.

Select **Next** and set the side to be machined to Solder Side. This causes the tracks to be mirrored so that they are machined correctly when looking from underneath.

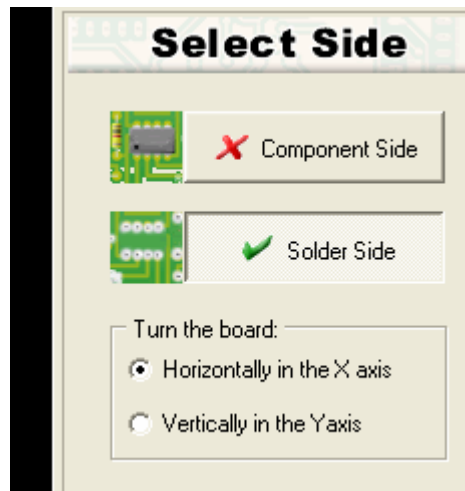

The next step is to calculate toolpath to cut the tracks on the PCB

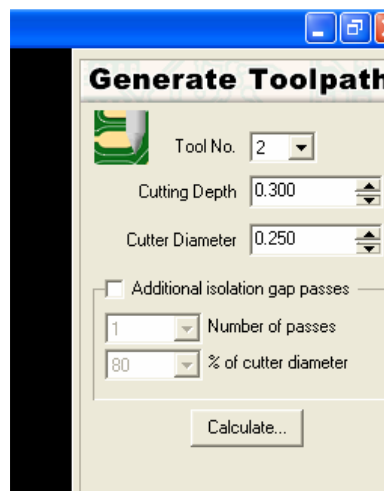

The toolpath is shown as a white line around the tracks.

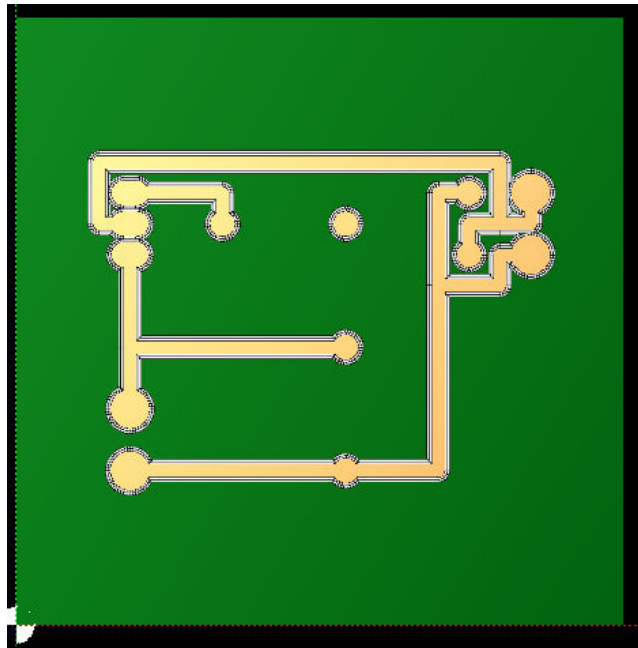

There is an option to generate additional passes to increase the isolation gap.

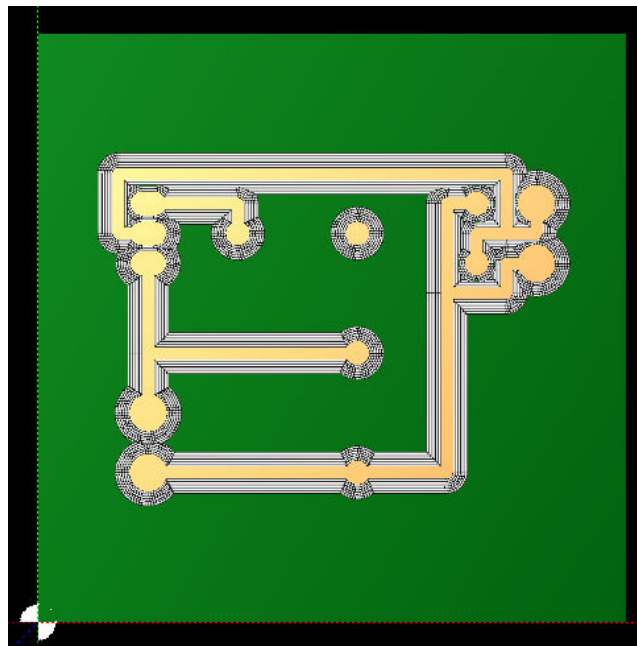

The additional passes can be seen above.

The next step is to load the drill file containing the hole data for the PCB. The file will have the same name as the Gerber but will have the extension **.drl**

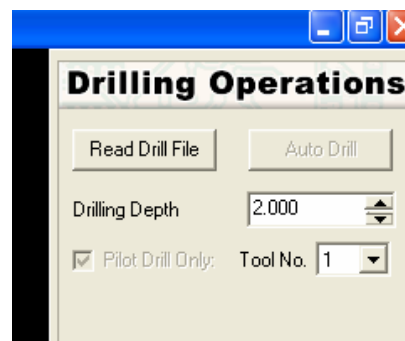

The drill locations will now be visible

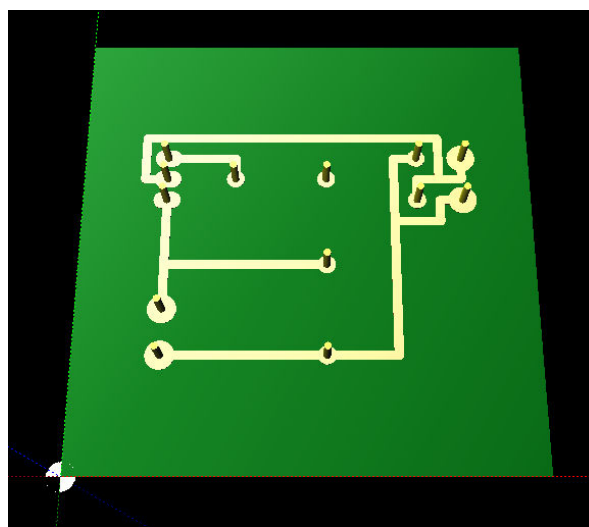

Once the drill file has been loaded, extra options appear depending on the drill data imported.

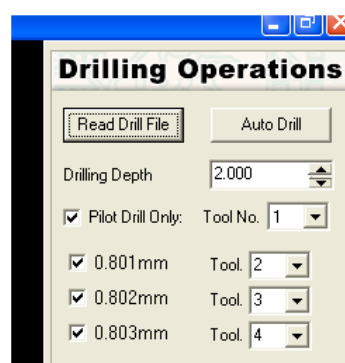

As this PCB will only be spot drilled, make sure the **Pilot Drill Only** box is checked before moving on.

The next step allows the speeds and feeds to be changed if desired. Leave them at their default values and move on to the next step

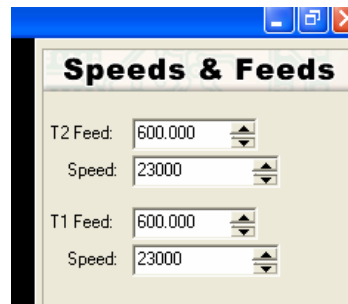

The final step is to generate a program to machine the PCB

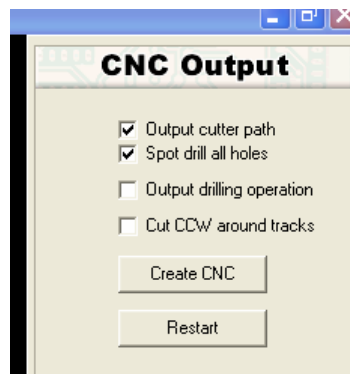

Make sure that the drilling output is turned off before creating the CNC program. The program can be simulated using the 2D/3D window as with the 2D Milling exercise. As the engraving tool is very small, the cuts are difficult to see with the normal solid simulation. They will become clearer if the **Show Toolpath** option is selected by clicking on the button on the top of the simulation window.

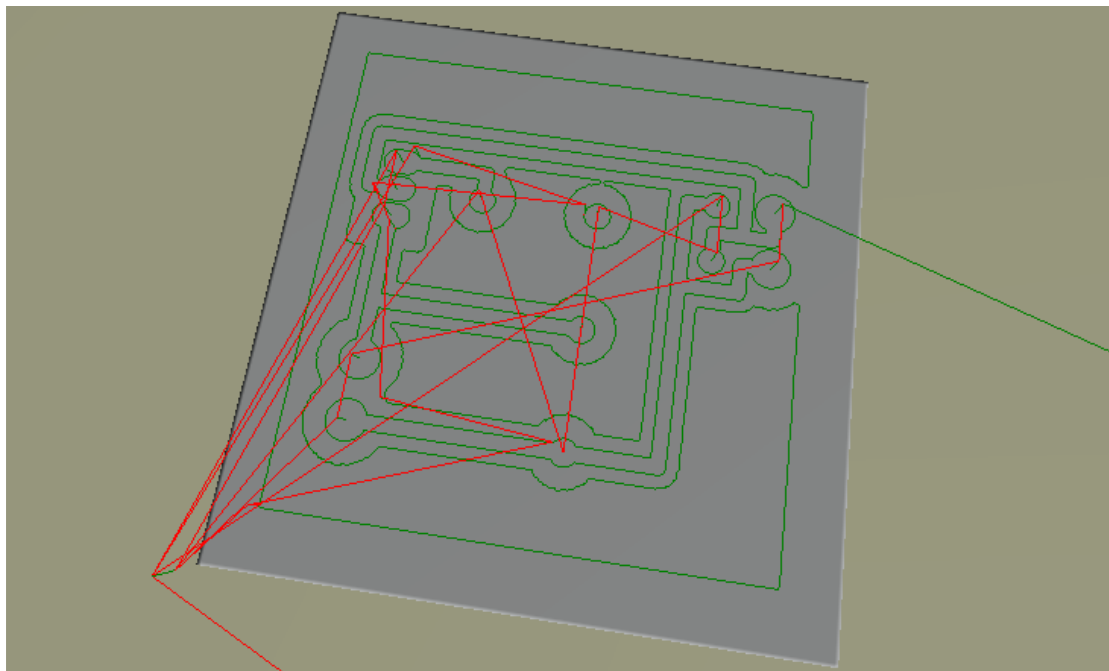

Producing the PCB on the Machine

Machining the PCB is very similar to producing the 2D part made earlier. Select **Real Machine** on the Right hand of the VR Milling window and run the program as before.

When setting up the PCB on the machine it is useful to have a block of non-porous, stable material such as Aluminium, Nylon or similar, large enough to support the PCB and high enough to lift it clear of the table. This block can be clamped to the machine table as normal and the PCB blank taped to its top surface using double sided tape.

If the front left corner of the block is set up as a datum then setting up the PCB blank is simplified and is a matter of aligning the corners of each.

Appendix 1

Setting up Machine and Tool Datum's on the Denford Compact 1000 Pro

This process basically involves fitting a tool to the machine spindle, positioning it where the datum should be on the material blank and storing this position in the machine's memory. The process is explained step by step below.

First power up the machine and start VR milling. The control panel for the machine should appear similar to that shown below. This is the basic interface for controlling the machine.

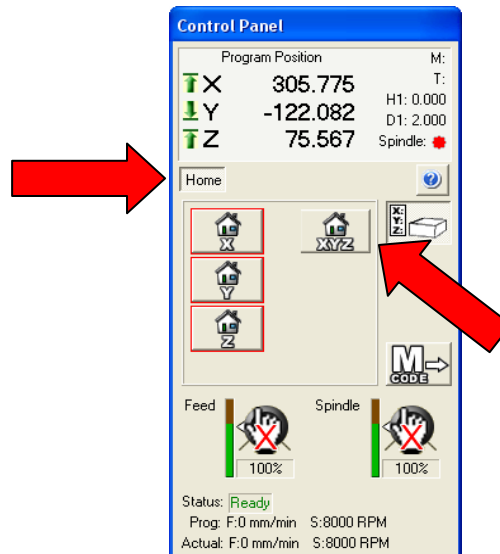

The machine will not do anything until the axes have been homed. Note that the only mode available is **Home**. Each axis can be homed individually or all three together by pressing the button indicated above.

On pressing the home button, the machine will move to the home position and the remaining modes will become available.

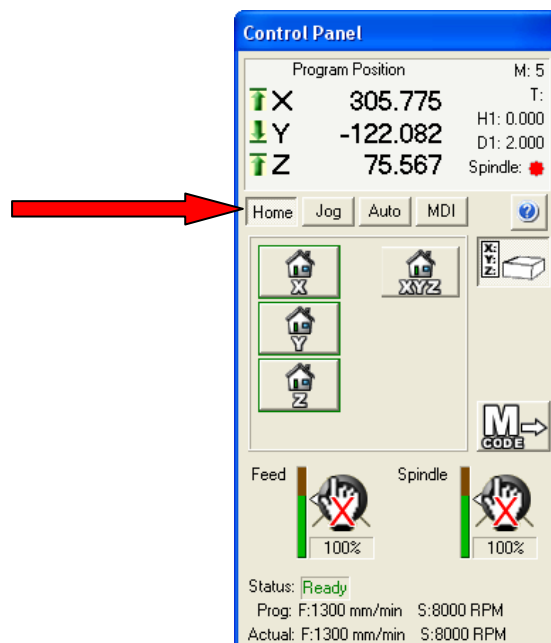

To position the tool at the X-Y Datum point, select the Jog mode and the window will change to the following:

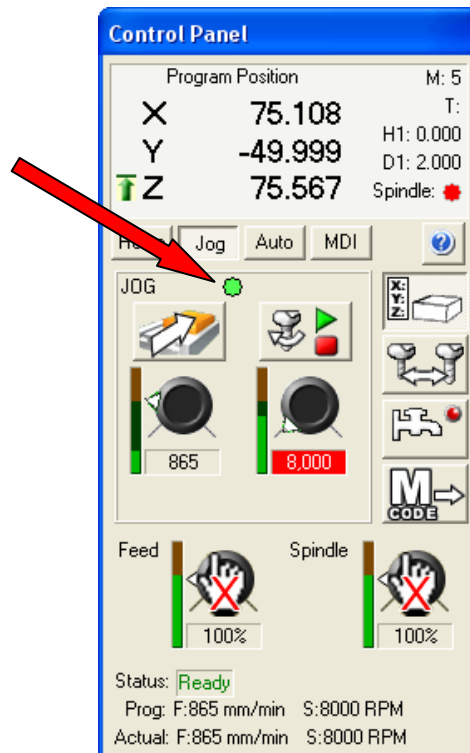

In order to work, the window must be active (i.e. clicked upon). The green button shown turns red when the window is inactive. When the Jog window is active the machine axes can be moved using the following keys on the computer keyboard.

- Right and Left arrow keys (X Axis)
- Up and Down arrow keys (Y Axis)
- Page Up and Page Down (Z Axis)



The axis motion can be continuous at a preset speed (e.g. 865mm/min shown in the figure)

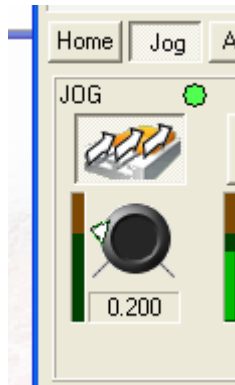

Alternatively, the jog can be set to move by a fixed amount for every keypress. (0.2mm in this instance)

In both modes, the step size / speed is adjusted using the black dial underneath the jog button.

Using a small step increment is particularly useful when approaching the top of the work piece with the tool when setting the Z datum. One way of setting the datum is to move the tool to within a small distance of the top surface of the material using constant motion and then to step down in small increments (0.1mm or less) until a strip of paper held under the tool is trapped between the tool and work piece.

For positioning the X and Y axes, lining the centre of the tool up by eye is usually good enough provided the item is being machined from an oversize blank.

Setting the Work piece Datum Point

Assuming that the tool has been positioned at the datum point on the work piece, the next task is to set this position up as the datum point for the machining. This is done using the **Tool and Offset Editor**. This can be toggled on and off by the button on the bottom left of the screen.



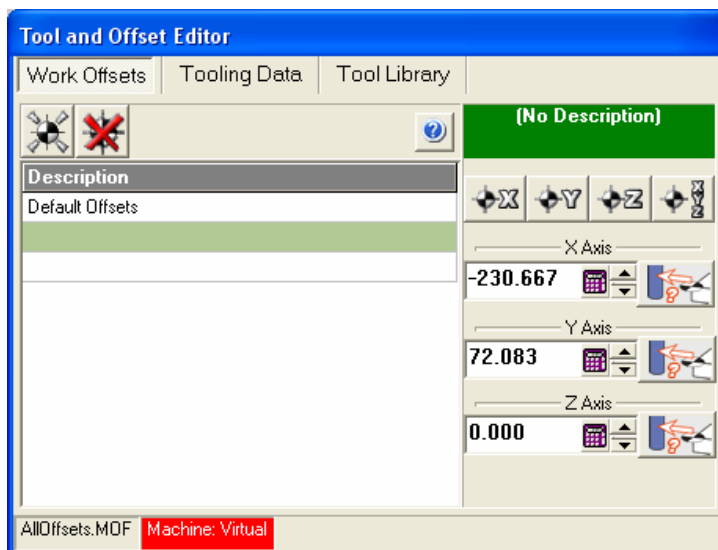

The tool datum is set and stored by defining a Work Offset to store the difference between the machine datum and the work datum for each of the X, Y and Z axes. If the **Work Offsets** button is selected the window should look something like that above.

To set the current position as a work offset, select the New Offset button on the top left of the window and type a name for the offset in the text box that appears below. Then select the XYZ button to store all three axis positions. (Alternatively, to even out error for large workpieces that may have an uneven height Select X and Y individually and set the Z datum at the centre of the work piece after moving there)

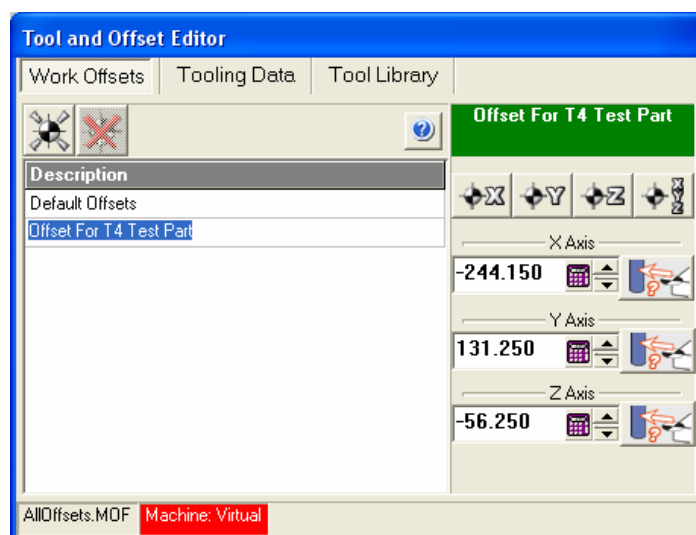

Once the offsets have been set, the values for the X, Y and Z axis offsets will change to reflect the current position from the machine datum. A number of work offsets can be defined and stored for later use. The work offsets can be recalled later if the same job is to be run again.

Defining Tools

In order to accurately machine a part, the software must know the dimensions of the tool being used. Tools are defined using the Tool and Offset editor and are accessible from the other software e.g. QuickCAM.

There is an extensive library of tools already defined in the Tool Library. These can be viewed by clicking on the Tool Library button

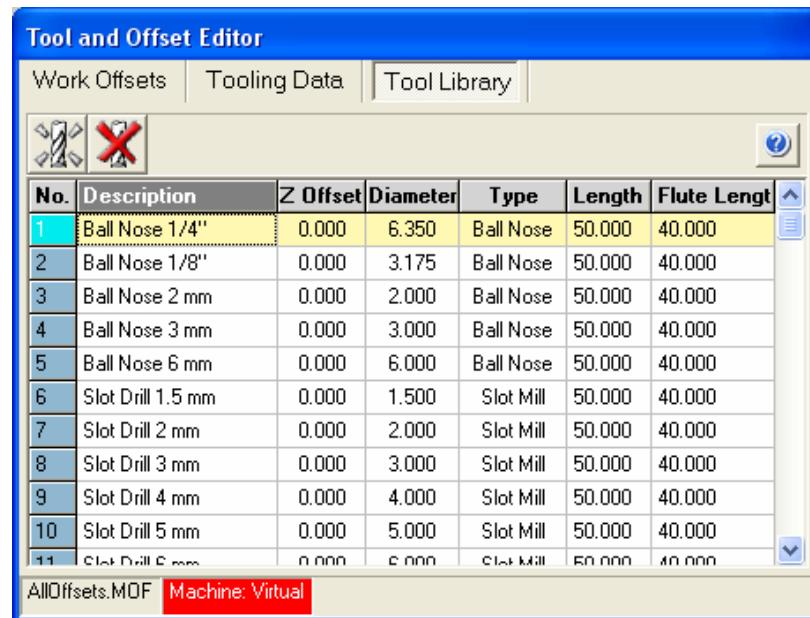

Tools can be added or removed from the library using the two buttons on the top left of the window.

To select the tools for use in a particular job, choose the **Tooling Data** button to show the list of active tools. The blank Tool Data window looks like this.

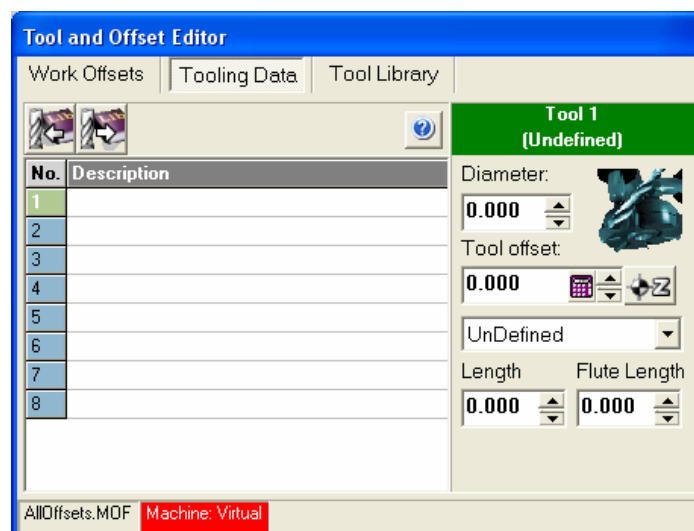

A tool can be added from the library by clicking the top left button to display a list of tools in the library

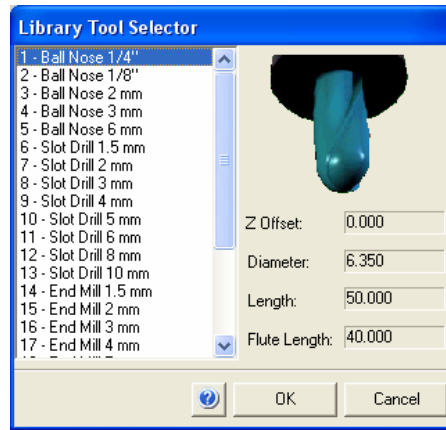

Choose an appropriate tool (Say 3mm Slot Drill) to add it to the list. If the list is blank it will be added as Tool No. 1. A meaningful name for the tool can be typed in the **Description** line or else, leave it as imported from the tool library.

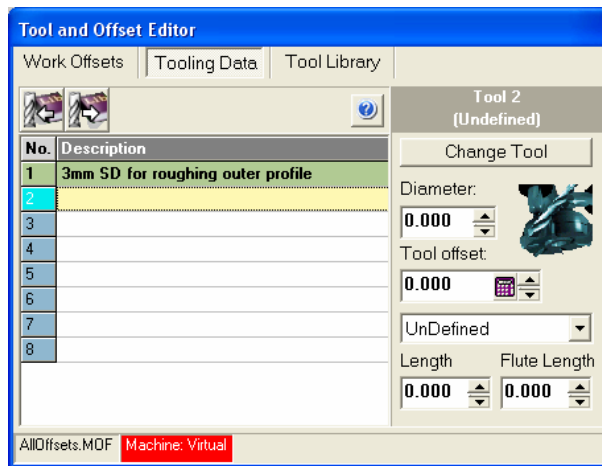

Add one more tool (Tool 2) which will be an engraving tool which will be useful for cutting PCBs later.

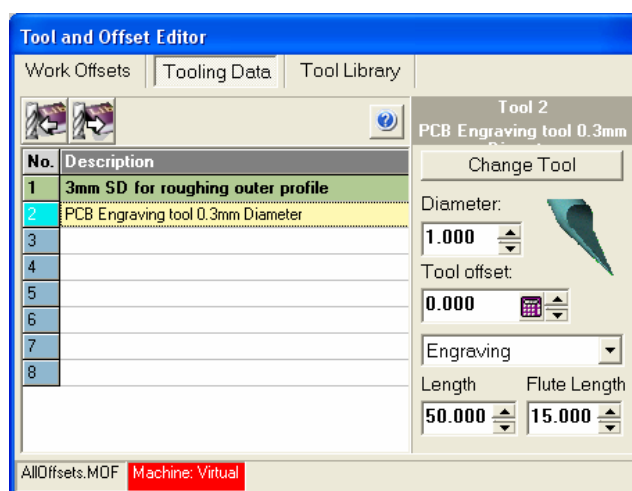

Once the tools and offsets have been defined, the Tool and Offset Editor can be hidden by clicking on the Icon at the bottom of the screen.

Appendix 2

File Transfer between Systems

All CAD and CAD/CAM systems differ in how they work and how they represent the drawing or part being modelled. For example, a 2-D CAD system will be concerned with lines, arcs, and their start and endpoints. A solid modelling system will need to deal with features such as extrusions/cuts and a design tree. A PCB design package will have information on tracks, pads and component values. All of these systems need to save their work to disk for later use.

As these systems have developed over time, each will have devised a file format that is most efficient for their particular needs. The format used will be specific to the type of information being stored e.g. lines/arcs and will typically use the least space on disk and load quickly when opened.

Native and Neutral File Formats

It is not surprising therefore that a wide variety of file formats exist for saving CAD/CAM data. Neither is it surprising that each filetype can usually only be read by the application it was designed for. (there are a small number of exceptions)

A list of commonly used file types is shown below. There are many more.

Application	Filename Extension
AutoCAD Drawing	.DWG
SolidWorks Part	.SLDPRT
SolidWorks Drawing	.SLDDRW
TechSoft 2-D Design	.DTD
Circuit Wizard	.CWZ
TechSoft PCB design and make	.DTB

If a particular system was to be able to read in the files from another then it would need to incorporate a routine to read, decode and convert the data stored within it. To read data from a variety of systems then a similar routine would be needed for each. It is easy to see that this would quickly become impractical if many file formats were to be supported.

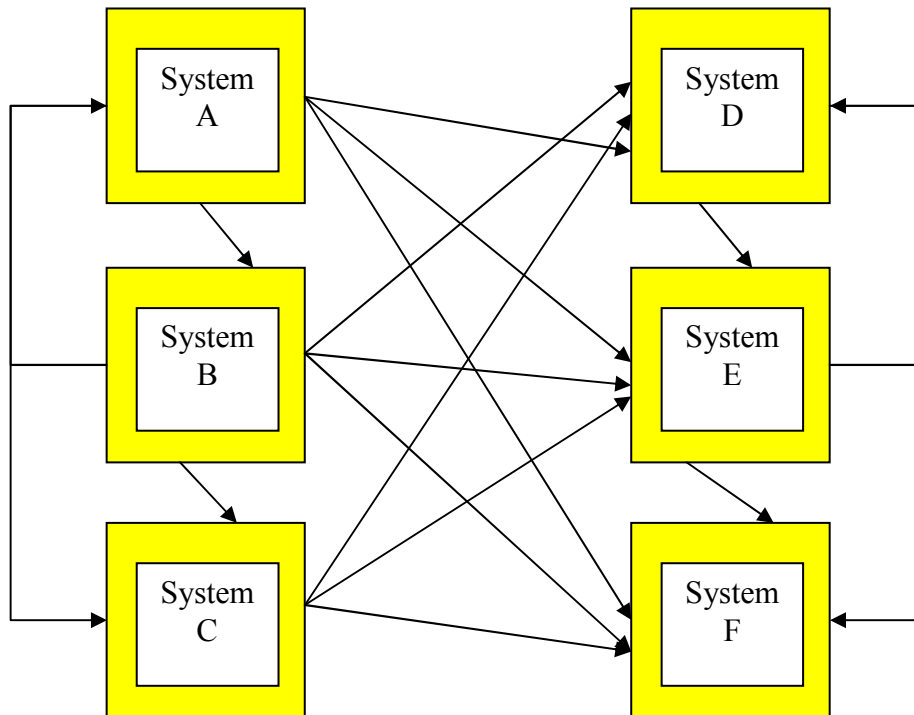

The partially complete diagram above gives an idea of this. Each of the arrows represents a conversion routine to another file format.

To further complicate matters, software manufacturers rarely publish the format of their native file formats and in any case they are prone to revision without notice as the software is updated and developed.

In practice, a neutral file format is usually used to transfer data from one system to another. The file format is published and understood by all.

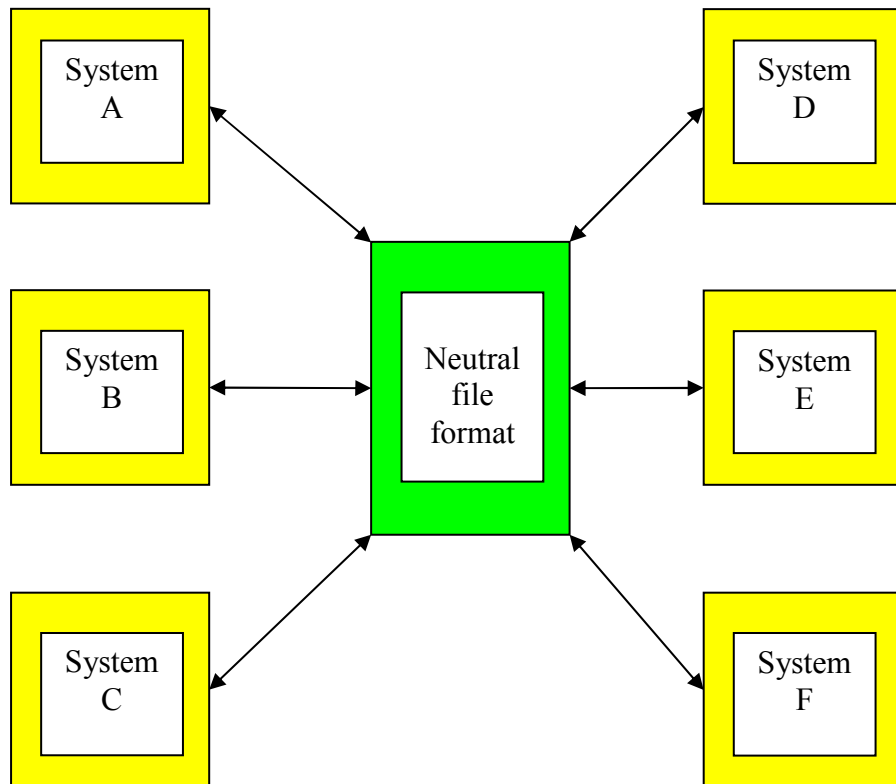

It can be seen that this arrangement is much simpler. Each software package needs only one translation routine to import from and to export to the neutral file format. To convert data from any system to any of the others, a file is exported in the neutral format and imported by the receiving system.

The neutral file format itself will by its nature be a compromise and there will often be some loss of system specific information (e.g. the design tree in SolidWorks) in the translation. However this does not pose a problem as these features are often not needed by the system subsequently reading the file, for example a machining program such as Visual Toolpath is only interested in the physical shape of the solid.

A few different neutral file formats have evolved over time, each with its particular strengths and applications. These are explained briefly on the following pages.

Drawing eXchange Format (DXF)

DXF was originally developed by Autodesk, the writers of AutoCAD as a neutral format for exporting and importing 2-D AutoCAD drawings. Although it supports 3-D, it is normally used for the transfer of 2-D graphical files between systems. It represents the items as lines, arcs, points, etc along with their coordinate data:

```
ENTITIES
0
LINE
5
27
100
AcDbEntity
8
0
6
CONTINUOUS
62
1
100
AcDbLine
10
128.6588971478
20
123.3424833098
30
0.0
11
```

Advantages:

It is supported by most 2-D graphical programs as well as the drawing editor in SolidWorks. DXF files are accurate to six decimal places and so are suitable where accurately produced parts are required.

Uses:

DXF is best used in the following situations:

- Exporting a SolidWorks *drawing* for 2-D machining
- Exporting a SolidWorks *drawing* for laser *cutting*

Limitations:

- The way DXF files represent text means that it will usually not be read by the system importing the file and text will often disappear altogether.
- DXF files are not suited for transferring drawings containing bitmaps or similar raster images.

In most software, DXF file creation is available as an option under either **File – Export** or **File – Save As...** and selecting the correct file type

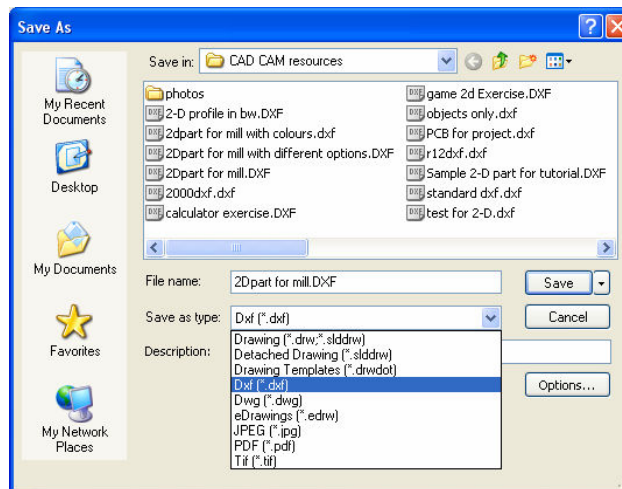

DXF files are imported similarly by using **File – Open** or **File – Import**

Sterolithography Files (STL files)

This file format was originally developed for transferring data between CAD systems and rapid prototyping (Stereolithography) systems. It is commonly used to transfer the *physical shape* of a solid modelled component from one system to another e.g. from SolidWorks to a 3-D Machining program for generating toolpath.

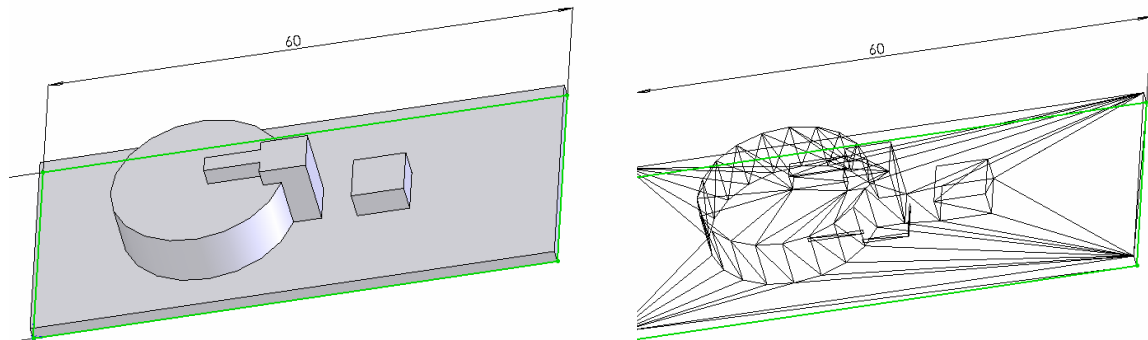

Figure 25 SolidWorks model of a part and its STL representation

In STL, the shape of the item is represented by a series of triangles that approximate its outer surface. The format can also show which side is the 'inside' and the 'outside' of the part. The accuracy of the shape can be controlled by increasing or decreasing the number of triangles but in general this is not necessary.

Advantages:

This is a quick and simple way of exporting a complex 3-D solid modelled shape to another system.

Uses:

Export of a 3-D solid modelled *part* to another system for machining (or rapid prototyping)

Limitations:

- All of the design and other information (colour, texture etc) are lost so this is not suitable for export to another CAD system for example that may want to use this data.
- It is not suitable for exporting/importing anything other than solid models

Windows Metafiles

These are the files that are created when items are cut and pasted using normal windows commands (Edit – Cut/Copy and Edit – Paste). Entities can be copied from one program and pasted into another. In some cases this is the only possible way to export/import between different software, and in many cases it greatly simplifies the process. There are some limitations however.

Advantages:

Allows the cutting and pasting of a wide variety of data such as text, pictures of all types, CAD drawings, across widely different software. For example a 2-D CAD drawing can be pasted directly into a word document, or into another CAD program or into an image editing program such as Paint in exactly the same manner.

Uses:

- When exporting CAD files containing text for laser cutting
- When exporting CAD files containing 2-D profiles for laser cutting (DXF preferred)
- When exporting raster images for laser engraving

Limitations:

- All the items are transferred using integer arithmetic and will appear as a 'picture' object when they have been pasted. This means that there is likely to be some loss of accuracy. It is usual to have to resize the pasted item back to its original size before processing.
- Effectively limited to any item that can be represented as a picture i.e. 2-D profiles, PCB layouts, raster images etc., not 3-D entities such as CAD models.

Gerber Files

Gerber Files resemble CNC programs in appearance and this gives some clue to their origin. They were originally developed to drive the Gerber Photoplotting machines that were used in producing masks for PCB manufacture. Gerber files can contain all of the manufacturing information relating to a PCB. Gerber files are usually generated in a set from a PCB design package, each file defining one aspect of the PCB. For example, one file will contain the details of the tracks (solder side) and another the sizes and layout of the components (component side), yet another the drill holes, and so on. The files are generated automatically using **File-Save As...** or **File – Export** option from the PCB design package.

PCB manufacturing programs are able to read Gerber files directly so this provides an easy means of transferring data from one system to another.

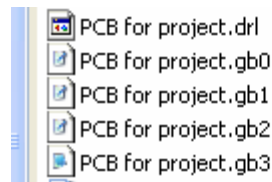

Uses:

Export PCB manufacturing data from CAD to CAM

Advantages

A well established and easy way to convert specialised data for PCB. Allows filtering out of unwanted items by ignoring certain files e.g. component side.

Limitations.

Useful for PCB manufacture only.

Origins of CAD/CAM

Introduction

The term CAD/CAM stands for Computer Aided Design and Computer Aided Manufacture. The two are often used together to describe a process where an artefact is designed electronically using a CAD system such as SolidWorks or AutoCAD with the information from the CAD drawing being used to manufacture the component directly using computer controlled equipment such as a milling machine or lathe. Over time, both CAD and CAM have evolved separately and the seamless combination of the two is a relatively recent development.

This module will assume a working knowledge of CAD and will concentrate on the manufacturing aspects of the process. There is a variety of CNC machine configurations, manufacturers and an even greater variety of processes available to the Technology teacher. It would be beyond the scope of this document to give a comprehensive treatment of each machine, each process and its associated software application. Instead, a general overview is given of what is possible and how this may be achieved. Then a machine specific example of each is presented with enough detail for it to be replicated in the classroom. In addition to this, a brief summary of the development of CAD/CAM is given as well as a section on the principles behind CNC.

History

Computer Numerical Control

All of the manufacturing equipment used involves controlling the movement of a cutting tool of some sort in a precise manner. Both the positional accuracy and speed of travel are important and these need to be controlled precisely in order to achieve the desired outcome. This control of the tool path is achieved by Computer Numerical Control (CNC) systems built into the machine tool. The systems have two aspects.

- How they control the motion of the cutting tool
- How they are programmed

In order to better understand how present day systems have come about it is useful to look at the development of CNC over time.

Early Numerical Control

As early as the late 1940s as the cold war between the US and Russia escalated, the American aerospace industry began to need complex aerofoil shapes to cater for aircraft and missile manufacture. These shapes were very difficult to machine by conventional processes and the first Numerical Control (NC) milling machines were developed for this purpose. The machines had what is known as a 'hard wired' control system and were capable of moving from one point to another in a straight line only. The programs were generated using a computer and loaded into the machine control one line at a time using punched paper tape. The programs consisted of long lists of coordinate data that were fed to the control, one line at a time for each move. This type of control did not have a computer and all of the control was achieved by the

(hard wired) circuitry of the control system. The machines were very expensive, very large and used almost exclusively by the aerospace industry.

CNC

The next major development came in 1975 with the advent of Computer Numerical Control. Computer Numerical Control uses a computer to perform the tasks formerly done by the hardwired system. These machines were much more flexible in operation. It was now possible to machine an arc by issuing a single command as the control could now calculate all of the intermediate points along the arc. CNC also featured 'canned cycles' where the drilling of a hole (or the cutting of a thread on a lathe) could be simplified to a single command. It was around this time, that CNC started to become commonplace and CNC lathes and Milling machines were used both to mass produce simple components and to manufacture difficult items such as cavities for injection moulds.

The machines were programmed by a text based programming system called Word Address, more commonly known 'G-Codes' because of the appearance of the program. The programs are commonly called 'part programs'. The programs are keyed directly into the machine control or else generated elsewhere and then downloaded to the machine. There is some variation in the format and syntax of word address programs due to different adaptations of it by a range of CNC control manufacturers. A fragment of a typical part program for a milling machine is shown in Figure 26 below

N5 G00 G90 X100.0 Y0.0 T1 M06	Rapid to tool change position. Load Tool 1
N10 G43 X5.0 Y-5.0 Z1.0 S1200 M03 M08	Move to start of profile. Start spindle
N15 G01 G41 Z-5.0 F100	Feed to depth
N20 X90.0	Linear cut along profile
N25 G03 X100.0 Y10.0 I0.0 J10.0	Circular arc move

Figure 26 Sample of a G-Code part program

Using this system, the programming of simple parts is relatively straightforward and making changes to a program is easy. However, manual programming by its nature is prone to error and for more complex shapes such as curved or sculpted surfaces the program needs to be generated from a CAD system.

CAD systems themselves originated around the same time as the early NC machines but remained expensive and therefore rare until the advent of cheap computing in the early 1980s when they started to become commonplace.

Having defined the shape of a part to be manufactured using CAD, the next logical step was to use the CAD geometry to generate a program for the CNC tool directly, thus eliminating the need to write programs like that shown in Figure 26 above. This approach is still common. Denford routers, for example, use a version of the language known as Fanuc-OM. (So called because it is used by the GE Fanuc CNC control which is fitted to many machines)

There is a variety of software packages available to generate programs.

These take the CAD data and 'post process' it to produce a CNC program that is then loaded into the machine control from the CAD computer using a cable.

This type of software combined with the CNC is commonly referred to a CAM system. (Computer Aided Manufacture). The entire process is usually referred to as CAD/CAM

The two most important functions a CAM program performs is to first add in extra information that the CAD drawing would not have such as cutting speeds, feeds, clearance moves, tool offsets etc. It then generates a G-Code program in the correct format for the machine it is being sent to. These programs are often very long (several thousand lines) as they are commonly used to machine items such as mould cavities where many short moves are required. The process is shown in Figure 27

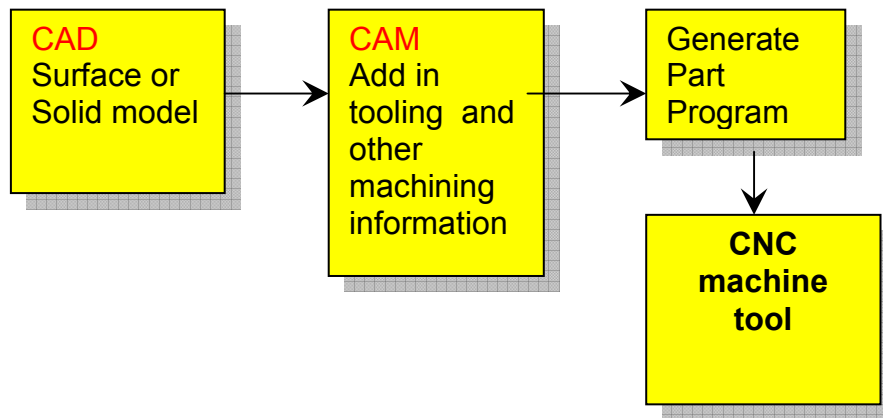

Figure 27 Schematic of the CAD/CAM process

CAM systems usually offer some means to preview the toolpath or simulate the cutting process before generating the program. They often offer a CAD-like drawing functionality that eliminates or reduces the need for a CAD system. There are a variety of CAM systems commercially available. AlphaCAM is one system that is popular with the manufacturing industry in Ireland at present.

Present Day

With the reduction of the cost of CNC systems and computing a variety of light desktop machines have emerged in recent years. These were originally aimed at the modelmaking industry and offered a low cost alternative for the cutting of soft materials such as wood and plastic. These machines often share many of the characteristics of a printer and offer a graphical programming system where the user has little or no need to interact with the programming language used by the machine. Unlike the complex user interfaces seen on full size CNC machine tools, these machines usually offer two or three buttons to perform the essential tasks such as setting up a cutting tool. The machines can be controlled using a printer driver or from other software on the computer. This effectively replaces the machine interface. This method is very simple to use and has been adopted widely in schools for routing machines, vinyl cutters, laser cutting etc.

Types of Machine

In CNC, the location of the cutting tool is specified by its position along two or more of the machine axes. An axis is can be considered as a degree of freedom (or a direction) along which the tool can move and roughly corresponds to the cartesian coordinates (x and y) used in CAD. With CNC, the situation is a little more complex however as explained below.

Axis Orientation

The axes of a CNC machine are defined by what is known as the right hand rule. If we take the thumb as pointing in the direction of the positive X-Axis then the second finger is pointing towards the positive Y-Axis and the middle finger towards the positive Z-Axis. The Z Axis always contains the spindle. This holds true for all machine tools including lathes.

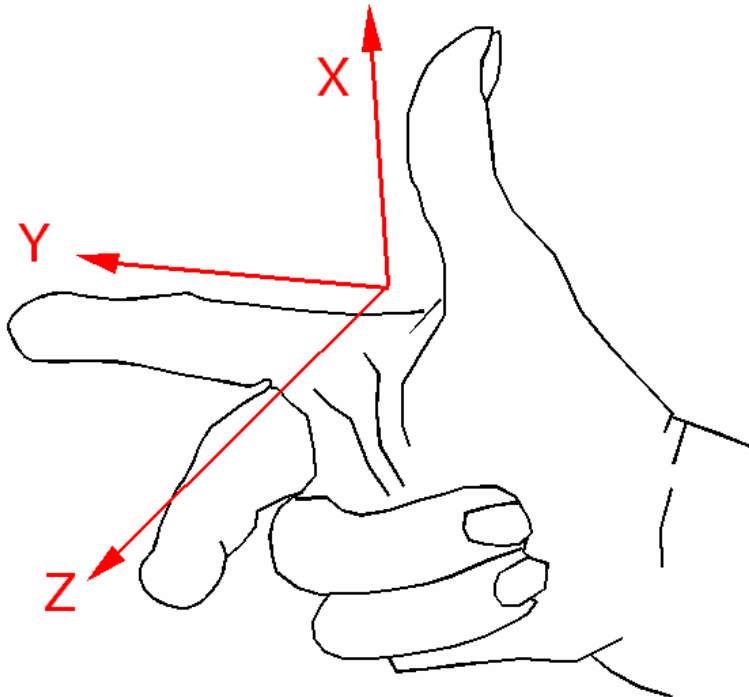

Figure 28 The right hand rule

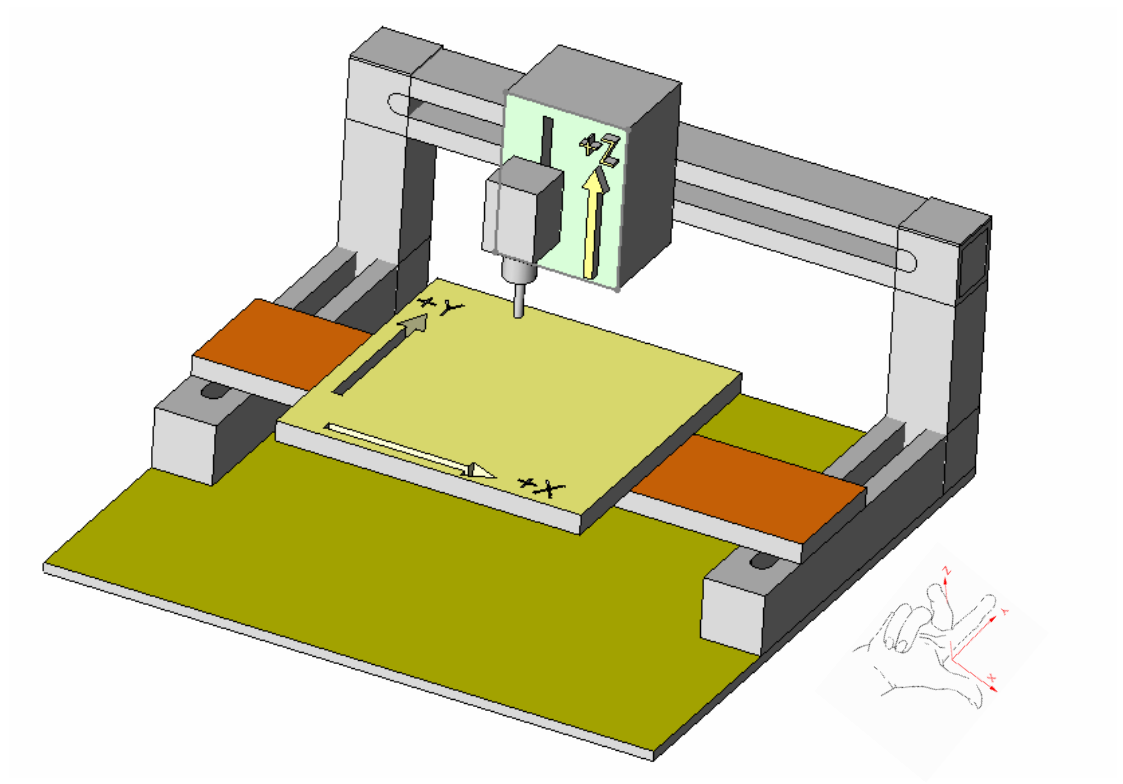

Figure 29 Axis orientation for Router

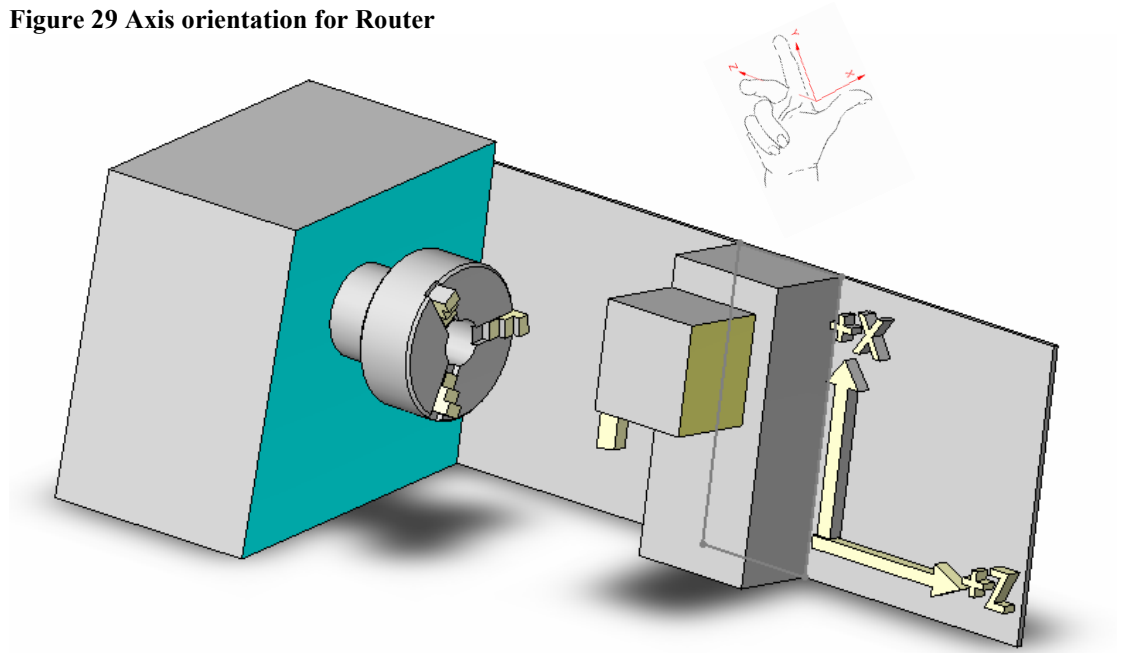

Figure 30 Axis orientation for Lathe. Note that the right hand rule applies here also.

CNC machines are often described by the number of axes that are controlled. A laser cutter would be classed as a 2-Axis device as motion is only controlled in the X and Y axes.

A CNC lathe is a 2-Axis where the tool is driven along the Z and X axes. A router would be a 3-Axis machine as motion is possible in X, Y and Z axes.

Beyond Three Axis Control

With some machines it is possible to fit a dividing head and/or rotary table to provide rotary motion of the work piece. In this case the motion is considered to be rotation about either the X, Y or Z axis. These rotary axes are usually labelled A, B and C respectively.

Therefore it is possible for a machine to have four, five and even six axis control. In practice more than four is rarely needed.

At least one desktop router manufacturer offers a fourth Axis dividing head. This type of configuration allows the machining the top, sides and underside surfaces of a component without the need to turn it over.

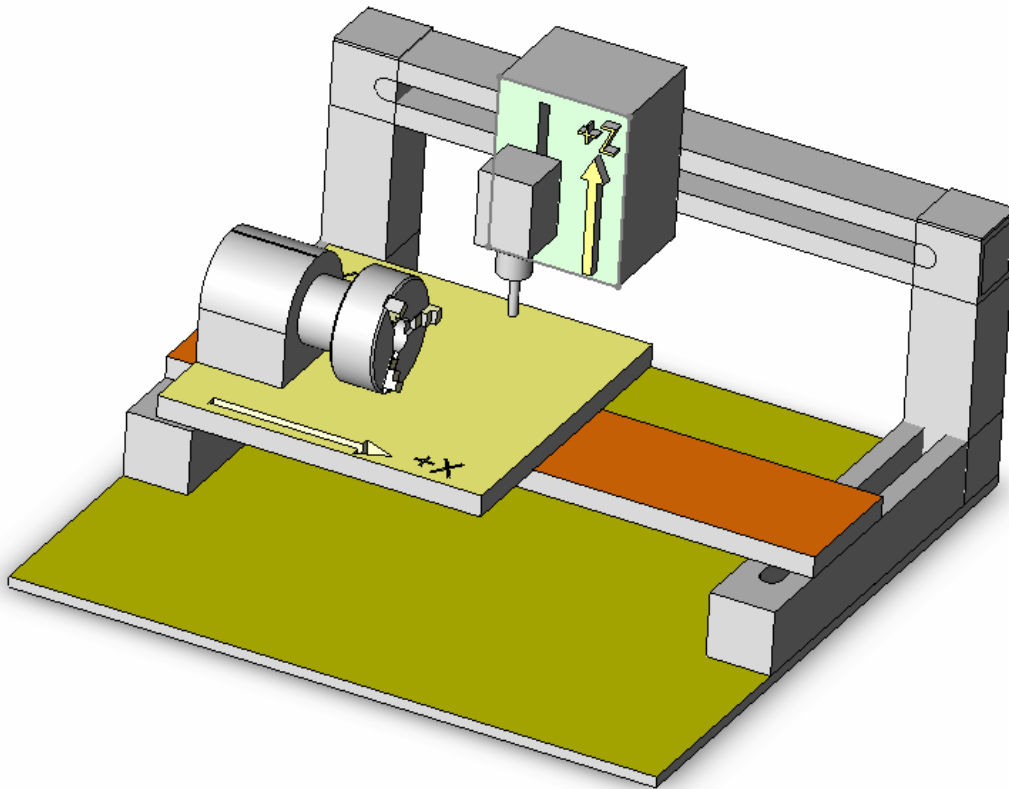

Figure 31 Router with a fourth rotary axis

Principles of a Practical CNC Control

All practical CNC systems contain three elements:

- The control
- Current Amplifiers
- Servo Motors

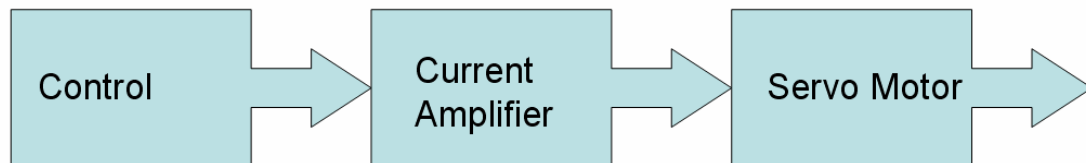

Figure 32 Block diagram of a CNC system

The control is the 'brain' of the system. The control reads the instructions from the program and performs all of the calculations and measurements that determine where the cutting tool should be for any given instant in time during the run of the program. This can be a complex process using advanced mathematical principles. The result is that the control can send signals to the servo motors to control the axis positions up to several hundred times per second. The type of signal sent depends on whether Open loop or Closed loop control is used – see below.

The output from the control is usually a small voltage (typically plus or minus five volts). In order to drive the servo motors a current amplifier is needed. This uses the voltage signal from the control (called the demand voltage) to control the current that powers the servo motors.

The servo motors are the final part of the system. There are two types commonly used.

Stepping motors are a specialised type of motor that moves in very small increments (steps) controlled by voltage pulses. A stepping motor typically rotates 1.8 degrees per pulse. If 200 pulses are sent to the motor it will turn through one complete revolution. The speed of the pulse train will control the speed of the motor. They are usually used with Open Loop control.

The second types of motors are AC or DC servo motors. These behave in a similar manner to a conventional AC or DC motor but are designed to provide more constant running characteristics. These motors will exert a torque in proportion to the current running through them. They are used with Closed Loop control only.

Open and Closed Loop Control

Open Loop

This is the simplest type of control and contains the three basic elements described in Figure 32 above.

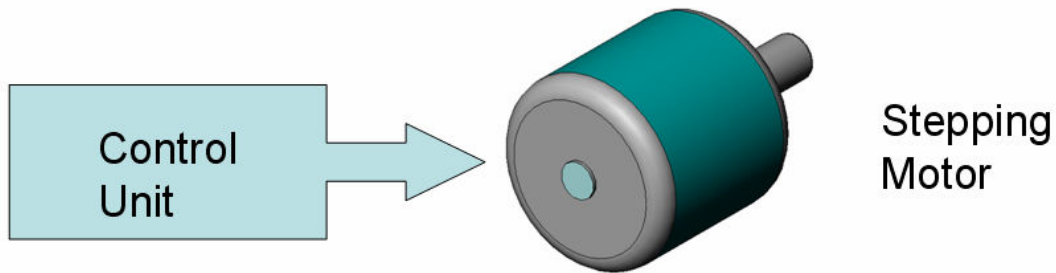

Figure 33 Elements of an open loop control

This is shown in more detail below

The open loop system works as follows: Say that the control has calculated that a particular axis needs to move a distance corresponding to 80 pulses at a constant speed equivalent to 10 pulses per second. The control will output the pulse train to achieve this which is then amplified and delivered to the motor. The stepping motor will travel the specified number of pulses and then hold in position until the next action. The control has no way of knowing whether the motor has actually received or travelled the full distance. Errors can occur if the motor misses a pulse or if it encounters an obstacle that causes it to stall.

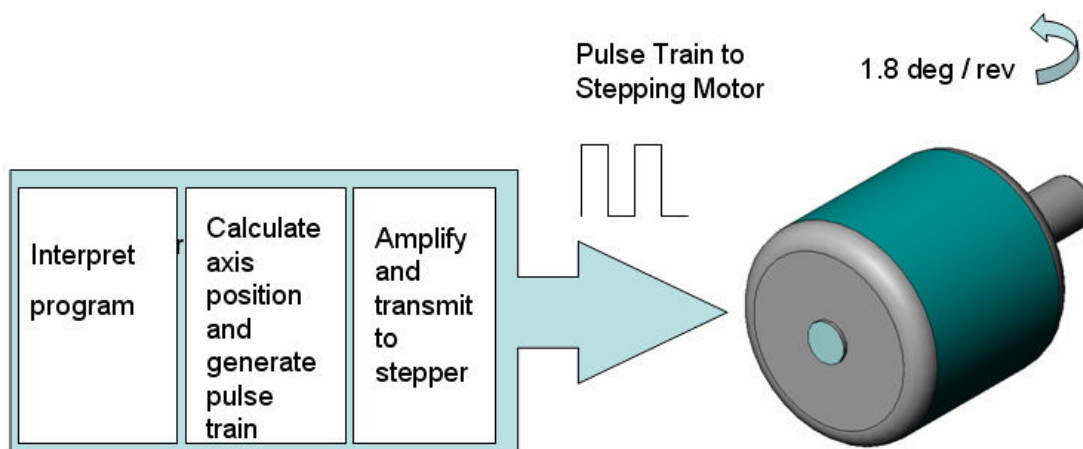

Figure 34 Open loop control system

This is not usually a problem where the forces acting on the stepping motor are low or where extreme accuracy is not critical. The advantage of open loop is its low cost and simplicity.

Closed Loop Control

This method of control has one additional element. Servo motors are used to drive the axes and an encoder is used to provide feedback of the servo position to the control. This allows the control to compare the actual position of the axis to where it should be at a rate of about 500 times per second.

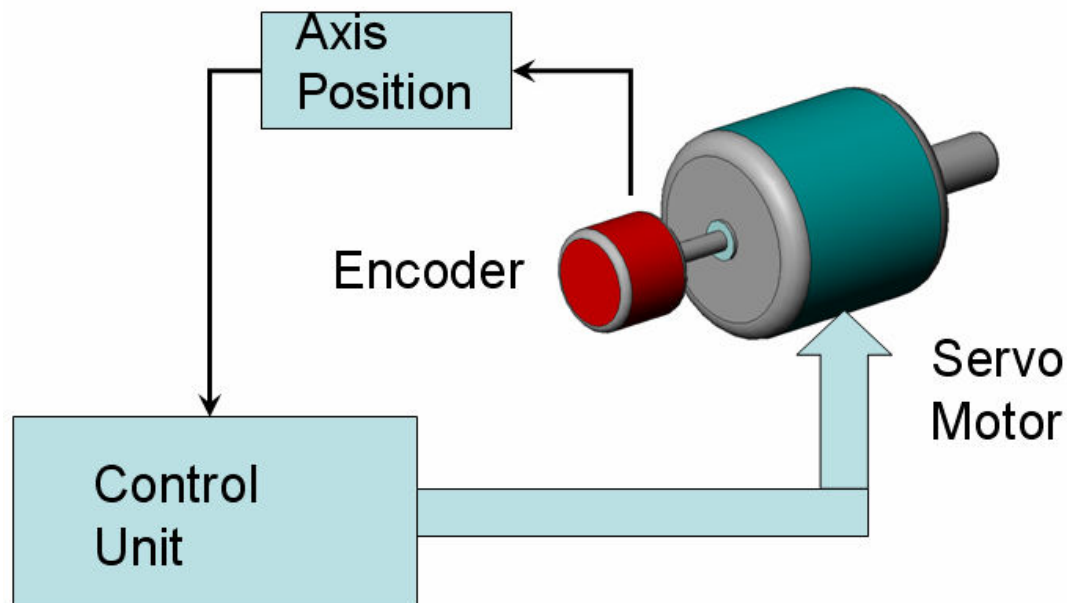

Figure 35 Elements of a closed loop control system

The control outputs a voltage in proportion to the amount of error. This voltage controls the direction of the servo and has the effect of trying to pull it towards its correct position. The greater the error the stronger the pull. If a particular axis is programmed to move say, 10mm at a speed of 1mm/s then it will calculate each intermediate position for the axis in 1/500 second intervals and then vary the demand voltage to pull the servo towards each of them over the course of the ten seconds taken to complete the move. Once the move is complete, if a force tries to move the axis out of position (say a collision with the cutting tool) the control will detect an error between the ideal and measured positions and will try to move the axis back into position.

It can be seen that this type of control is more reliable and offers greater accuracy than the open loop system described earlier. Closed loop systems are used widely in CNC equipment and robotics and they are the norm in all but the simplest systems.

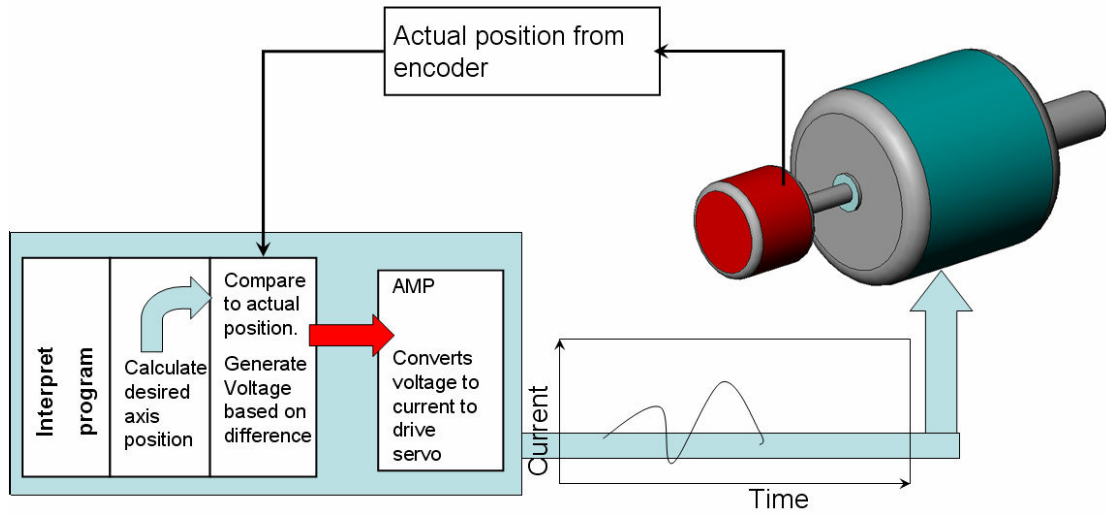

Figure 36 A Closed loop control system